

## BUKTI KORESPONDENSI JURNAL NASIONAL TERAKREDITASI SINTA 2

Judul Artikel : Physicochemical Quality of Oyster Mushroom for Functional Food (ID 7244).

Jurnal : Jurnal Teknik Pertanian (JTPEP) Volume 12 No.4, (December 2023): 818-830. Jurnal Nasional Terakreditasi Sinta 2

Penulis : Helmi Haris, Ridwan Rachmat, Tiana Fitrilia , Ahmad Syarbaini, Amar Ma'ruf, Dede Djuanda, Naila Fathi Isnazaki Hafiyya, Aulia Dinda Wahyuni, Wildan Saputra dan Restu Akim

No	Perihal	Tanggal
1b.1	Balasan surat bahwa akun sudah ter- registrasi	23-05-2023
1b.2	Bukti ACTIVE SUBMISSIONS	24-05-2023
1b.3	Artikel yang di submit	24-05-2023
1b.4	Submit Awal	27-05-2023
1b.5	Editor Decision	18-07-2023
1b.6.a	Hasil Review dan Revisi dari Reviewer 1	18-07-2023
1b.6.b	Hasil review dari Reviewer C 18-07-2023	18-07-2023
1b.6.c	GABUNGAN REVISI DARI REVIEWER 1 DAN 2	18-07-2023
1b.7	Under proses Review	31-07-2023
1b.8	Accepted latter-Helmi Haris	25-08-2023
1b.9	CE 7244-20230731-WA0033	09-09-2023
1b.10.a	the result of the improvements according	11-09-2023
1b.10.b	REVISED-CE 7244-20230731-WA0033	15-09-2023
1b.11	Bukti Publised JTPEP Vol. 12, No. 4 (2023) 818 - 830	17-10-2023

## 1b.1. Balasan surat bahwa akun sudah ter- registrasi

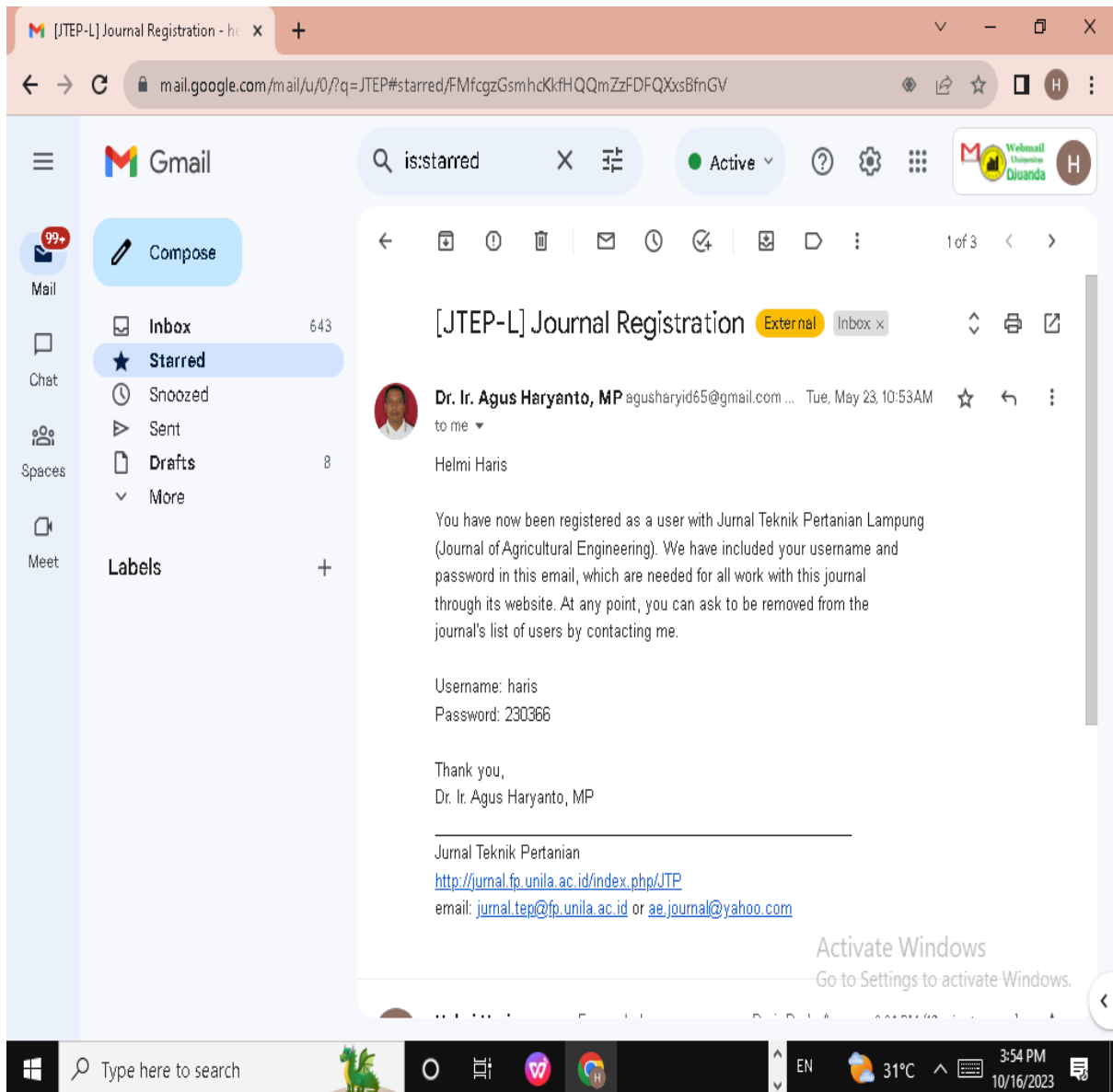

The screenshot shows a Gmail interface on a Windows desktop. The browser address bar displays the URL: `mail.google.com/mail/u/0/?q=JTEP#starred/FMfcgzGsmhcKkfHQQmZzFDFQXxsBfnGV`. The search bar contains the text "is:starred". The left sidebar shows the Gmail navigation menu with "Starred" selected. The main content area displays an email from "Dr. Ir. Agus Haryanto, MP" (egusharyid65@gmail.com) dated Tuesday, May 23, 10:53 AM. The email subject is "[JTEP-L] Journal Registration" and is marked as "External" and "Inbox". The recipient is "Helmi Haris". The email body contains the following text:

You have now been registered as a user with Jurnal Teknik Pertanian Lampung (Journal of Agricultural Engineering). We have included your username and password in this email, which are needed for all work with this journal through its website. At any point, you can ask to be removed from the journal's list of users by contacting me.

Username: haris  
Password: 230366

Thank you,  
Dr. Ir. Agus Haryanto, MP

Jurnal Teknik Pertanian  
<http://jurnal.fp.unila.ac.id/index.php/JTP>  
email: [jurnal.tep@fp.unila.ac.id](mailto:jurnal.tep@fp.unila.ac.id) or [ae.journal@yahoo.com](mailto:ae.journal@yahoo.com)

An "Activate Windows" watermark is visible in the bottom right corner of the email content area. The Windows taskbar at the bottom shows the search bar, taskbar icons, and system tray with the date and time: 3:54 PM, 10/16/2023.

## 1b.2. Bukti ACTIVE SUBMISSION

The screenshot displays a Gmail interface on a Windows desktop. The browser address bar shows the URL: `mail.google.com/mail/u/0/?q=JTEP#starred/FMfcgzGsmhcKkfHQQmZzFDFQXxsBfnGV`. The search bar contains `is:starred`. The left sidebar shows the 'Starred' folder selected, with 1 email. The main content area shows an email from **Dr. Ir. Agus Haryanto, MP** (`agusharyid65@gmail.com`) received on Tuesday, May 23, 10:53 AM. The email body contains the following text:

Helmi Haris

You have now been registered as a user with Jurnal Teknik Pertanian Lampung (Journal of Agricultural Engineering). We have included your username and password in this email, which are needed for all work with this journal through its website. At any point, you can ask to be removed from the journal's list of users by contacting me.

Username: haris  
Password: 230366

Thank you,  
Dr. Ir. Agus Haryanto, MP

Jurnal Teknik Pertanian  
<http://jurnal.fp.unila.ac.id/index.php/JTP>  
email: [jurnal.tep@fp.unila.ac.id](mailto:jurnal.tep@fp.unila.ac.id) or [ae.journal@yahoo.com](mailto:ae.journal@yahoo.com)

An 'Activate Windows' watermark is visible in the bottom right corner of the email content area. The Windows taskbar at the bottom shows the search bar, task view, and system tray with the date 10/16/2023 and time 3:54 PM.

## 1b.3. Artikel Yang Disubmit

### Exploration of Oyster Mushrooms for Functional Fresh Food

Helmi Haris<sup>1</sup>, Ridwan Rachmat<sup>2</sup>, Tiana Fitrilia<sup>1</sup>, Ahmad Syarbini<sup>1</sup>,  
Amar Ma'ruf<sup>1</sup>, Dede Djuanda<sup>1</sup> and Dian Histifarina<sup>2</sup>

*<sup>1</sup>University of Djuanda, Bogor, West Java,  
Jl. Raya Ciawi Bogor, West Java, Indonesia*

*<sup>2</sup>Research Center for Appropriate Technology, National Research and Innovation Agency  
Jl. K.S. Tubun No 5, Subang, West Java, Indonesia*

**Abstract.** This article presents studies on the physicochemical quality of oyster mushrooms grown within a housing and controlled by the Internet of Things (IoT). The goals of this study were to assess (1) the impact of indoor air quality on the growth and quality of mushrooms and (2) the antioxidant content of oyster mushrooms. In this study, the air temperature and humidity per unit mass of oyster mushroom per unit time will be recorded and automatically controlled by an IoT system. Additionally, their physicochemical and microbiological quality were evaluated using physico-analytical instruments, and the potency of their ergothioneine (EGT) content was investigated using the HPLC method. The temperature of the air inside was between 29 and 35 degrees Celsius, and the relative humidity was between 60% and 90%. The weight of fresh oyster mushroom was 865 mg. The length, width, and height of the fresh mushroom were measured to be 41.5 mm, 60.0 mm, and 29.5 mm, respectively. The microbiological test confirmed that there was no salmonella infection in the collected mushrooms. The button-stage mushrooms have less total fungus than the bloom-stage mushrooms. The extraction standard method employs an EGT content of 0.674 mg/g as determined by chromatography data analysis. The oyster mushrooms can be consumed as a healthy meal, and the study of EGT showed also very prospective as one of immunotherapeutic food.

**Keywords:** ergothioneine, Fibre-reinforced plastic house, Internet of think, oyster mushrooms

## INTRODUCTION

The oyster mushroom is a type of mushroom that specifically grows in tropical countries such as Indonesia. oyster mushrooms are grown on aggregate media one of them is the paddy waste from the paddy cultivation. Therefore, generally at the rice production centre area mostly becoming the centre for mushrooms production. This can be correlated with the availability of biomass as the main growing media for mushroom.

Cultivating high quality of the mushrooms required high-quality seeds, the high-quality media resources as well as the optimal environment due to the mushrooms are sensitive to climate change. To fulfil the optimum condition for mushrooms cultivation, an adequate production house is required to be implemented by environment controller and high-quality safety materials for growing media and to avoid using industrial in order to produce free contaminant (Kopinski, and Kwiatkowska-Marks, 2012).

A prototype of Fiber Reinforced Plastic (FRP) house (Ridwan Rachmat and Horibe, 1999) is a proper construction for mushroom production housing, and it is implemented with an Internet of things (IoT) based connected to various devices microcontroller. The mushroom production house used IoT control system is to make it easier to monitor the air condition inside the house online by mean of displaying the value generated from the installed sensors inside the house. According to Shasha Asyarita & Ani Lestari [7],

temperature and humidity in production house of mushrooms greatly affect the growth process of mushrooms. So that the mushrooms do not rot, brown and wilt, the humidity in the mushroom production house should not be too high or low, ranging from 75%-90% at the humidity level of the mushroom production house.

Research by Dhiya et al [5] who conducted an analysis of the efficiency of the edible mushroom stated that the growth of high consumption of mushrooms was due to the high protein content of edible mushrooms. The mushroom has good properties for the nutritional needs of the human body such as being rich in protein, vitamin C and various water-soluble vitamins (riboflavin, biotin and thiamine), fat (5.7%), carbohydrates (56,8%), amino acids, unsaturated fats, essential minerals (sodium, potassium and phosphorus) and has a low calorific value [6].

Mushrooms contain various types of nutrients those are beneficial to the health of the human body, such as carbohydrates, proteins, and fats. Several types of essential nutrients found in edible mushrooms include amino acids (glutamic acid, proline, phenylalanine, lysine, histidine, etc.), fatty acids (lauric, palmitic, oleic, lenoleic, etc.), potassium, calcium, and phosphorus (Adiandri et al., 2018). One type of essential amino acid found in mushrooms is ergothioneine (EGT). EGT is a derivative of histidine which contains functional groups of sulfur atoms and hydrogen atoms (-SH) and it can only be synthesized by fungi and actinobacteria (Borodina et al., 2020; Halliwell et al., 2018).

Mushrooms as a food source have been reported to have the highest level of ergothioneine compared to any other food source ([Dubost et al., 2006](#), [Dubost et al., 2007](#)). In an early report, it has been shown that if we consume mushrooms as our regular food, the bioavailability of ergothioneine remains in our body ([Weigand-Heller et al., 2012](#)). The ergothioneine chemical compound is accumulated in the fruiting bodies as well as in the mycelia of the mushroom ([Borodina et al., 2019](#), [Kalaras et al., 2020](#)). Several studies have been conducted with samples of mushrooms to describe improved ergothioneine production by the addition of several additives, such as aspartic acid, lysine, and methionine, which demonstrate increased ergothioneine biosynthesis ([Lee et al., 2009](#)). In addition, it has also been described that the production of ergothioneine increases with increased pH and is higher under alkaline conditions ([Huang et al., 2015](#)).

Research on the identification and isolation of EGT from several fungal varieties has been carried out. The content of EGT in mushrooms is quite high and has good antioxidant activity. In addition, differences in genus and species of fungi have different chemical compositions contained in them so that it affects the proportion of EGT in mushrooms (Kalaras et al., 2017). The results of the literature study indicate that the identification and isolation of EGT from edible mushroom has never been done. Therefore, research to explore the opportunity to use edible mushroom as a source of EGT needs to be done.

The provision of production house that meets food safety requirements is absolutely necessary to produce safe oyster mushrooms for consumption. Meanwhile the technology development of this mushroom production that meets food safety standards for the isolation of ergothioneine as an antioxidant is a potential matter in exploration of mushroom is still limited. This paper describes the research results of the prototype of FRP house with the air condition variation inside the house and the effect of air condition against mushroom quality. The effect of the IoT implementation in controlling the air condition system as well as minimizing the human contact during oyster mushroom growing during cultivation periods, and to explore the value added of mushroom through the ergothioneine (EGT) analysis as the of antioxidant content in mushroom.

## MATERIAL AND METHODS

The scope of research includes (1) constructing a prototype of FRP house with IoT control system for oyster mushroom cultivation; (2) to evaluate the air condition variation inside the house and the effect of air condition against mushroom growth and quality; (3) Analysis of antioxidant content in mushroom. The materials and chemicals used in this research are analytical grade chemicals. The effectiveness of antioxidant properties on isolated EGT was measured by in vitro method.

### FRP House

The FRP house built in a prototype scale (Figure 1) at an area of 650 cm x 350 cm with a light steel alloy as the frames and the roof is covered by a thin metal sheet and all the wall blanketed by fibre reinforced plastic (FRP), and white tile's floor, there are two shelves at inside the FRP house with two racks of 400 cm length and 100 cm width respectively.



Figure 1. Prototype of FRP house model of straw mushroom

The FRP House implemented with an Internet of Think (IoT) system (Figure 2) to actuate a set of devices to measure the parameters of air temperature, air humidity, moisture content of the media. The control devices are 30 nozzles of mist sprayer setup along the rack of shelves above the media which are connected with a special hose. Hot air temperatures above 35°C, caused the exhaust fan is on, whenever a drastic drop of air temperature inside the FRP house below 29°C, thus the heater mixer will operate automatically to increase the room temperature. The controller specification showed in Table 1 are set at day and night time with the elapsed time of intervals are enable to monitor the parameters conditions to avoid disturbance during mushrooms growth.

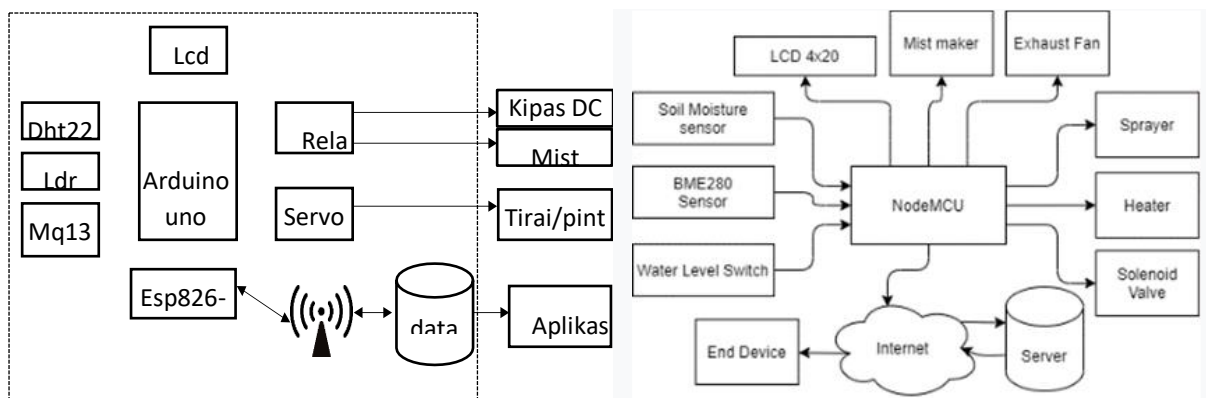

Figure 2. Architecture of IoT of production house in oyster mushroom

The Arduino Node MCU is an open-source platform based on IoT, which is able to implement various commands with programming languages. The application of the C programming language uses a sketch on the Arduino IDE (Integrated Development Environment), which is capable of programming various kinds of microcontrollers including Node MCU. The Node MCU has a small size compared to Arduino UNO, by using the ESP8266 module, there are GPIO (General-purpose input/output), PWM (Pulse Width Modulation), I2C, UART (Universal Asynchronous Receiver Transmitter), 1-Wire and ADC (Analog) to Digital Converter).

Tabel 1. Component and specification of control system.

Component	Specifications
Sensor BME280	Air temperature and Humidity sensor
Soil Moisture sensor	Soil moisture content controller
Water Level sensor	Water height controller
Mist-maker	Fog production and controller
Exhaust fan	Air humidity controller
Arduino IDE 1.8.9, Fritzing	temperature and Humidity

### Cultivation Process Procedure

Mushroom cultivation process procedure was carried out inside FRP House and utilized the organic components which are mixed and fermentation process for 4 days to be a compost, and then fill into bag log evenly in a plastic sacks assembled inside FRP House. The layers of compost were pasteurized inside FRP house with closed cover condition tightly and then fogging with hot air at temperature 60-65°C for 8 hours. The mushroom seeds were inside over the bag logs of compost and then to be incubated for 3 days at around 29-30°C of inside air temperature. The treatment during mushroom growth up to harvest periods comprised of the inside air temperature, humidity and soil water content.

### Extraction of the Active Compound Ergothioneine

The isolation of ergothioneine EGT compounds from the harvested fresh mushrooms was carried out by the extraction method refers to the method developed by Ito et al. (2011) and Nguyen et al. (2012) with some modifications. Pre-treatment (blanching and non-blanching), mushroom before drying methods by electric oven drying.

The experimental factors of extraction employed the temperature 40°C and 60°C respectively with the variation of the extraction solvent (water and ethanol 30% (v/v), 50% (v/v), 70% ethanol (v/v), and ethanol 100 % (v/v)). The extraction procedure utilized 10 grams of dry mushroom powder and 200 mL of solvent which has been heated in a shaking water bath according to variations in temperature. The solvent along with the solute was continuously agitated at 100 rpm for 1 hour, then cooled at room temperature for 2 hours. Then it was centrifuged at 600 rpm for 15 minutes at 25°C. The achieved of the process is supernatant which was transferred to a conical tube for further evaporation using a vacuum evaporator at a temperature of 40°C to evaporate the remaining solvent up to be a paste of EGT extract. Furthermore, the paste of EGT was dried by the freeze-drying method. The dried EGT sample was then weighed to measure as the extraction yield.

### **EGT concentration analysis**

Analysis of the concentration of EGT in the oyster mushroom extract used the HPLC method referring to the method used by Kalaras et al. (2017) with some modifications. The mushroom powder (0.5 g) and 7 ml of ethanolic was put into a 15 ml centrifuge tube (consisting of 10 mM dithiothreitol, 100 M betaine, 100 M 2-mercapto-1-methyl imidazole) and 3 ml of distilled water was added and homogenized with a vortex for 10 seconds. A total of 2 mL of 1% SDS solution dissolved in ethanol was added and homogenized with a vortex for 10 seconds. Then the suspension was centrifuged for 20 minutes at 4000 rpm and 25°C. The supernatant formed was transferred to a 15 mL centrifugation tube. Then, 1 mL of the supernatant was put into a micro tube and allowed to stand for 24 hours. The solid formed from this process is then dissolved into 0.5 mL of aqua bides and homogenized using a vortex until it dissolves completely. Samples that have been stored in micro-tubes were centrifuged at 10,000 rpm for 1 minute. The supernatant formed was then filtered using a syringe filter (0.45 100 m) and put into a glass vial for HPLC analysis.

HPLC analysis was performed using column C18. The volume of the solution injected was 10 µL. The mobile phases used mobile phase A (3% acetonitrile, 0.1% TEA, 50 mM dibasic sodium phosphate dissolved in distilled water), mobile phase B (acetonitrile), and mobile phase C (water). The separation was performed on the elution gradient as follows: 0 minutes 15:85 (B:C), 0-5 minutes set at a slope of 5:15:85 (A:B:C), 5-6 minutes set at a slope of 10:90 ( B:C), 6-8 minutes at 3:97 (B:C), and 8-15 at 3:97 (B:C). EGT was detected at a wavelength of 254 nm with a peak retention time of 5.7 min which was quantified using an external standard curve.

The antioxidant activity of EGT from edible mushroom was carried out by measuring the radical scavenging activity of DPPH referring to the method of Pahila et al. (2019). The analytical procedure comprised of 50 L of straw mushroom extract is added to 50 L of DPPH solution (100 M in 85% ethanol) and stirred using a vortex. After 15 minutes, the solution mixture was put into a 50 L Pyrex NMR capillary tube, then the DPPH radical spin resonance was measured with a spectrometer at a wavelength of 517. The spectrometer settings as microwave power, 1.2 mW; microwave frequency 9149.3 MHz; field magnet, 325.5 25 mT; and the sweep time, 30 seconds. Various concentrations of EGT were measured for resonance to construct a standard curve. The radical scavenging activity of DPPH was expressed as mmol equivalent of EGT per mL of sample.



## RESULTS AND DISCUSSION

### FRP House

The prototype of the FRP house is shown in Figure 3. Condition of the air temperature, air humidity and water content of the media inside the FRP house during mushroom cultivation are monitored automatically. The variation of air temperature around 29-39°C is relatively stable, while condition at day, night and rainy, resulted in high fluctuated of air humidity 40-98% with the water content of the media around 39-99%.

The devices inside the mushroom's FRP house consists of circuits, input blocks and output blocks which are joint by the Nodemcu microcomputer to control the air condition inside mushroom's FRP house. The input block is a soil moisture sensor and BME280 as a temperature, humidity and barometric detector. The sensor will generate an input value for the Nodemcu microcomputer, this value will be processed by Nodemcu which produces an output value to the connected devices. While the output block is a receiver a value generates by sensor through Nodemcu, such as a heater will operate if the temperature inside the mushroom's FRP house is low and the mist-maker will turn off if the humidity inside the mushroom's FRP house is sufficient. Nodemcu has a Wi-Fi module that is able to save the values and data in the database, this can make it easier to use a smartphone to access mushroom's FRP house condition even the values or data remotely. The IoT control system is setup for operating the hot air exhaust with the mist sprayer process taking place in parallel if the air temperature at above 39°C with humidity below 60%. And when the opposite condition occurred (below 29°C), thus the water heater will actively operate spraying hot air vapor into the FRP House. This methods of IoT control mechanism will reduce the human intervention so that the growth process of mycelium and pinhead of fungal embryos can achieve optimally.

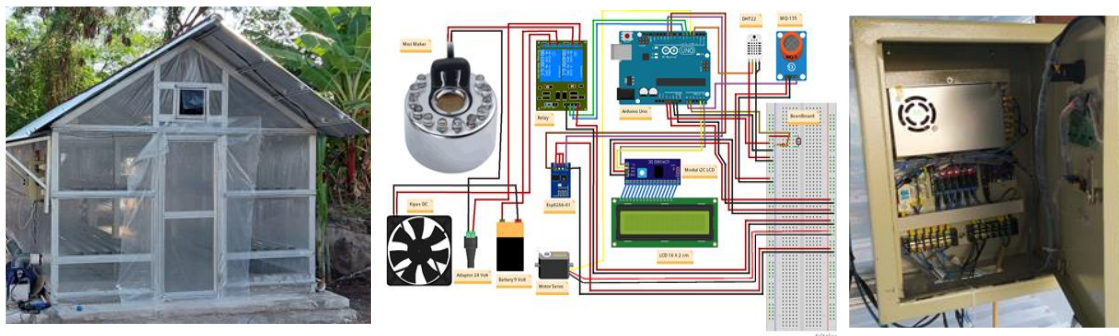

Figure 3. The prototype of the FRP house with IoT circuit

The generated measuring instrument and sensors performance corresponded the proposed elapsed time through the interface to display's monitor. In table 2 showed the comparison of sensor values with measuring instruments. Digital measuring instrument used to compare sensor values such as Hygrometer, lux meter and the average temperature difference of 0.7°C and humidity of 2.1%.

Table 2. Temperature and humidity sensor testing

Temperature			Humidity		
Sensor	Device	Diff	Sensor	Device	Diff
31.7	30.8	0.9	77	76	1
31.6	30.7	0.9	78.3	77	1.3
31.7	30.7	1	78.9	78	0.9
31.8	30.7	1.1	78.3	78	0.3
31.8	30.7	1.1	79.1	79	0.1
31.8	31.3	0.5	80.2	79	1.2
32.2	31.1	1.1	83.4	82	1.4
32.2	31.2	1	82	82	0
32.1	31.5	0.6	81.3	81	0.3
32.1	31.1	1	81.2	81	0.2

Table 3 is a comparison graph of sensor values with measuring instruments. Digital measuring tools used to compare sensor values such as mini-Hygrometer, lux meter and carbon detector. The test was carried out by taking samples 30 times by getting an average temperature difference of 0.91 0C, humidity 0.89%. Furthermore, the light sensor gets an average difference of 19.76% and gas content of 10.13 ppm. The second test evaluates the performance of the tool and obtains an accuracy rate of success of 93.3%.

Table 3. Light sensor and CO<sub>2</sub> content

light			Gas Content		
Sensor	Device	Diff	Sensor	Device	Diff
192	175	17	21	10	11
187	144	43	33	12	21
182	152	30	16	9	7
103	100	3	24	16	8
170	145	25	22	20	2
-	-	-	-	-	-
-	-	-	-	-	-
144	124	20	18	7	11
169	123	46	10	3	7
118	115	3	15	8	7
124	121	3	24	16	8
128	122	6	30	20	10

### Effect of FRP House to Mushroom quality

Air conditions and lighting inside mushroom's FRP house day and night during the mushroom growth (Figure 4) contribute for the effect to the quality of harvested fresh mushroom. The results of quality analysis indicated that the range of phenotype length of 2.5-10 cm, diameter of 3-10 cm and weight 10-120 gram (Figure 5), in general the mushrooms

growth from organic media are longer and heavier than non-organic growth media with more uniform dimensions except for the diameter of phenotype.

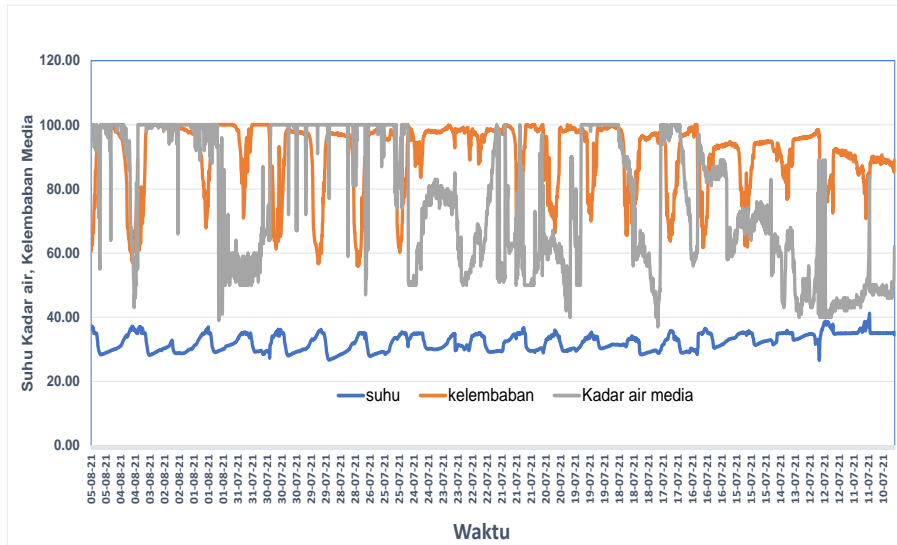

Figure 4. Condition of air temperature, RH, and moisture content inside FRP House



Figure 5. Dimension of harvested oyster mushroom

The hardness test per fruit and the moisture content of the mushrooms were carried out by comparing the mushrooms on organic media and non-organic media on the FRP house with the housing at the farm level as shown in Table 4, indicating that the mushrooms in the model FRP house were harder and less water content than that ones in the farmer mushroom's housing at the farm level.

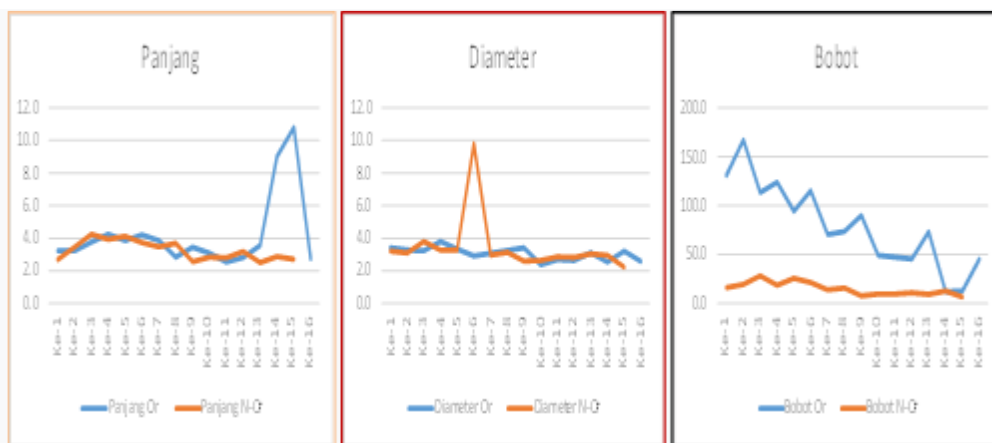

Figure 6 Dimension of fresh harvested mushroom

Table 4. Characteristics of straw mushroom

No	Parameter	average
1.	texture	865,0±100,0
2	Dimension	
	- Length (mm)	41,5±6,0
	- Width (mm)	60,0±4,0
	- Height (mm)	29,5±9,0

### Micro Laboratory Analysis

The results of micro-laboratory analysis (Table 6) showed that the fresh harvested mushroom are negative from total fungus and salmonella

Tabel 5. Analysis result of total fungus and salmonella

Code	Phase of fungus	Total fungus (cfu/g)	Salmonella (negative/25g)
A	Non organic mushroom, Bloom	$2.9 \times 10^5$	negative
B	Non organic mushroom, fresh	$1.0 \times 10^5$	negative
C	Organic mushroom, bloom	$3.5 \times 10^4$	negative
D	Organic mushroom, fresh	$6.5 \times 10^4$	negative
E	non organic mushroom, bloom	$1.7 \times 10^6$	negative
F	non organic, mushroom, fresh	$5.4 \times 10^4$	negative

### Extraction of the Active Compound Ergothioneine

The results of the analysis on functional compounds of EGT in oyster mushrooms using the HPLC method, a graphic recording of the results of HPLC analysis of dried

mushrooms with standard ethanol solvent. The average recording results from the EGT chromatography results were 0.674 mg/g as shown in Table 6

Table 6. Results of chromatogram graphic data processing from mushroom extract

Code	Area	Intercept	Slope	V (ml)	fp	B.s (g)	C (ppm)	C (%)	mg/g DW
Organic, et 70%	2,005	0,1501	0,0643	20	250	0,2006	719032,64	71,90	0,799
	2,0309	0,1501	0,0643	20	250	0,2006	729072,50	72,91	0,810
Non organic, et 70%	2,2289	0,1501	0,0643	20	250	0,2688	601370,99	60,14	0,668
	2,2626	0,1501	0,0643	20	250	0,2688	611119,98	61,11	0,679
Ethanol 96%	2,2255	0,1501	0,0643	20	250	0,2034	793432,33	79,34	0,882
	2,0676	0,1501	0,0643	20	250	0,2034	733066,64	73,31	0,815
Powder, organic	1,3702	0,1501	0,0643	20	250	0,2022	469216,53	46,92	0,521
	1,3862	0,1501	0,0643	20	250	0,2022	475369,69	47,54	0,528
Powder, anorganic	1,3431	0,1501	0,0643	20	250	0,2009	461763,43	46,18	0,513
	1,2709	0,1501	0,0643	20	250	0,2009	433817,65	43,38	0,482

The extraction process breaks down the bonds among the molecules of the material so that EGT and phenol compounds are produced with varying concentrations depending on the type of solvent used (Table 7). The results of the standard solution analysis showed that the EGT compound had a retention time of  $3.33 \pm 0.06$  minutes, while the mushroom sample showed a retention time of 3.28 to 3.30 minutes.

Table 7. Recapitulation of EGT characterization data from edible mushrooms

Solvent	Concentration EGT (mg/g DW)	Total Phenol (mg/g DW)
Ethanol 96%	$0,805 \pm 0.01$	$0,015 \pm 0.00$
Ethanol 70%	$0,848 \pm 0.05$	$0,025 \pm 0.00$

The extraction process using 70% ethanol produced higher concentrations of EGT and phenol than the extraction process using 96% ethanol. This shows that 70% of ethanol solvent is more effective used to bind EGT and phenol compounds in oyster mushrooms than that in pure solvents. This result is in line with the previous study conducted by Nguyen et al. (2012). The process of extracting the *Flammulina velutipes* mushroom using 70% ethanol was able to produce EGT and phenol compounds with higher concentrations than that the extraction using 50% and 100% of ethanol, with values of  $2.05 \pm 0.18$  mg/g and  $3.65 \pm 0, 08$  DW, consecutively.

The extraction process that has been carried out can break down the bonds between the molecules of the material so that EGT and phenol compounds are produced with varying concentrations depending on the type of solvent used (Table 8). The results of the standard solution analysis showed that the EGT compound had a retention time of  $3.33 \pm 0.06$  minutes, while the straw mushroom sample showed a retention time of 3.28 to 3.30 minutes.

Table 8. Methods and varying concentrations type of solvent for EGT

Species of mushroom	Methods	Concentration Ergothioneine (mg/g BK)
<i>Flammulina velutipes</i> Ref.: Nguyen et al. (2012)	water	$1.50 \pm 0.21$
	Ethanol 70%	$2.05 \pm 0.18$
	Methanol 70%	$1.86 \pm 0.04$
	Acetone 70%	$1.92 \pm 0.07$
<i>Pleurotus eryngii</i>	Hot water	0.86
<i>Pleurotus citrinopileatus</i>	Ref.: Yen et al. (2018)	3.73
<b>Oyster Mushroom</b>	<b>Ethanol 70%</b>	<b><math>0.67 \pm 0.01</math></b>

The extraction process for active compounds (Table 9), such as EGT and phenol, is influenced by several factors, such as solvent polarity and process conditions. A mixture of solutions has the ability to bind the active compound better than the pure solvent. This is due to the mixing of nonpolar solvents with water which can increase the polarity index of the solvent so that the extraction efficiency increases.

In addition, the increase in extraction temperature was positively correlated to the increase in antioxidant activity and polyphenols (flavonoids and total phenol), while the increase in extraction time was not positively correlated to the increase in antioxidant activity and polyphenols. In addition, the presence of agitation during the extraction process also contributes to increasing the extraction yield. This happens because the agitation process can increase the rate of diffusion and minimize the barriers to mass transfer from the solid surface into the solution (Muhamad et al., 2014).

Table 9. the results of chromatograph analysis of mushroom samples

Code	Area	V (ml)	fp	B.s (g)	C (ppm)	C (%)
Organic	2,005	20	250	0,20	719032,6	71,90
Non organic	2,2289	20	250	0,27	601371,0	60,14
Ethanol 96%	2,2255	20	250	0,20	793432,3	79,34
Flour (organic)	1,3702	20	250	0,20	469216,5	46,92
Flour (unorganic)	1,3431	20	250	0,20	461763,4	46,18

Table 10 showed that the role in synthesizing EGT is the methyltransferase enzyme which is encoded by the EGT gene and specifically remodels histidine into EGT compounds (Stampfli et al., 2020). The results of another study stated that the biosynthesis of EGT is a complex synthesis process involving various types of amino acids and carbon sources. However, in principle there are three types of amino acids that play an important role in EGT biosynthesis, namely methionine, histidine, and cysteine. Histidine acts as a starting material that plays a role in the whole series of EGT biosynthesis. Cysteine serves to provide a source of sulfur atoms, while methionine which contains the protein S-adenosyl-l-methionine (SAM) acts as a precursor in reactions involving methyl groups. In supporting its growth, cells can use dextrose, fructose, glycerol, maltose, and sucrose as carbon sources. A suitable carbon source for EGT biosynthesis is glycerol because it is able to maintain cells in a longer stationary growth phase. In the glycolysis cycle, glycerol is broken down into glycerol-3 phosphate by the enzyme glycerol kinase. Furthermore, glycerol-3 phosphate is broken down by the enzyme glyceraldehyde-3 phosphate dehydrogenase to glyceron-P which is then overhauled by triosephosphate isomerase to glyceraldehyde 3 phosphate (GAP). GAP acts as a precursor in the glycolysis process to produce pyruvic acid which will also be a substrate in the Krebs cycle. Consumption of large amounts of pyruvic acid can stimulate enzymatic reactions of amino acids to produce EGT (Yu et al., 2020).

Table 10. Concentration of ergothioneine in different species of mushroom.

<b>Mushroom Species</b>	<b>Ergothioneine Content*</b>	<b>Mushroom Species</b>	<b>Ergothioneine Content*</b>
<i>Fomitopsis pinicola</i>	0.07 ± 0.01	Polyozellus multiplex	0.51 ± 0.01
<i>Ganoderma applanatum</i>	0.06 ± 0.02	Ramaria botrytis	0.29 ± 0.03
<i>G. lucidum</i>	0.08 ± 0.02	<i>S. granulata</i>	0.09 ± 0.03
<i>G. neo-japonicum</i>	0.07 ± 0.00	Lampteromyces japonicus	0.43 ± 0.16

\*mg/g dw; Mean ± SD.

Sources: Modified from [Lee et al., 2009](#), [Ito et al., 2011](#).

## CONCLUSION

The research results showed that the cultivation of oyster mushroom with a kumbung with ceramic floors and plastic walls and an IoT management. The temperature of the air inside was between 29 and 35 degrees Celsius, and the relative humidity was between 60% and 90%. The weight of fresh oyster mushroom was 865 mg. The length, width, and height of the fresh mushroom were measured to be 41.5 mm, 60.0 mm, and 29.5 mm, respectively. The microbiological test confirmed that there was no salmonella infection in the collected mushrooms. The stage of mushrooms have less total fungus than the bloom-stage mushrooms. The extraction standard method employs an EGT content of 0.674 mg/g as determined by

chromatography data analysis. The oyster mushrooms can be consumed as a healthy meal, and the study of EGT showed also very prospective as one of immunotherapeutic food.

## REFERENCES

- Adiandri, R.S., Hidayah, N., dan Nugraha, S. 2018. Identification of amino acid, fatty acid, mineral content and respiration rate of straw mushroom in different stage of maturity. Proceeding the international seminar on tropical horticulture, 239-248
- Borodina, I., Kenny, L.C., McCarthy, C.M., Paramasivan, K., Pretorius, E., Roberts, T.J., van der Hoek, S.A, dan Kell, D.B. 2020. The biology of ergothioneine, an antioxidant nutraceutical. *Nutrition Research Review*, 33, 190-217
- Cheah, I.K., dan Halliwell, B. 2020. Could ergothioneine aid in the treatment of coronavirus patients? *Antioxidants*, 9, 595
- Dhalsamant, K., Dash, S.K., Bal, L.M., dan Panda, M.K. 2015. Effect of perforation mediated MAP on shelf life of mushroom (*Volvariella volvacea*). *Scientia Horticulturae*, 189, 41-50
- Halliwell, B., Cheah, I.K., dan Tang, R.M.Y. 2018. Ergothioneine – a diet-derived antioxidant with therapeutic potential. *FEBS Letters*, 592, 3357-3366
- Ito, T., Kato, M., Tsuchida, H., Harada, E., Niwa, T., dan Osawa, T. 2011. Ergothioneine as an anti-oxidative/anti-inflammatory component in several edible mushrooms. *Food Sci. Technol. Res.*, 17(2), 103-110
- Jamjumroon, S., Wongs-Aree, C., McGlasson, W.B., dan Sriloang, V. 2012. Extending the shelf-life of straw mushroom with high carbon dioxide treatment. *Journal of Food Agriculture and Environment*, 10(1):78-84
- Kalaras, M.D., Richi, J.P., Calcagnotto, A., dan Beelman, R.B. 2017. Mushrooms: a rich source of the antioxidants ergothioneine and glutathione. *Food Chemistry*, 233, 429-433
- Kopinski, L., dan Kwiatkowska-Marks, S. 2012. Utilization of waste newspaper using oyster mushroom mycelium. *Industrial & Engineering Chemistry Research*, 51, 4440-4444
- Nguyen, T.H., Nagasaka, R., dan Ohshima, T. 2012. Effects of extraction solvents, cooking precedures and storage conditions on the contents of ergothioneine and phenolic compounds and antioxidative capacity of cultivated mushrooms *Flammulina velutipes*. *International Journal of Food Science & Technology*, doi: 10.1111/j.1365-2621.2012.02959.x
- Nur Sakinah, M.J., Misran, A., Mahmud, T.M.M., Abdullah, S., dan Azhar, M. 2020. Evaluation of storage temperature, packing system and storage duration on postharvest quality of straw mushroom (*Volvariella volvacea*). *Food Research*, 4(3), 679-689
- Pahila, J., Ishikawa, Y., dan Ohshima, T. 2019. Effects of ergothioneine-rich mushroom extract on the oxidative stability of astaxanthin in liposomes. *Journal of Agricultural and Food Chemistry*, 67, 3491-3501
- Repine, J.E., dan Elkins, N.D. 2012. Effect of ergothioneine on acute lung injury and inflammation in cytokine insufflated rats. *Preventive Medicine*, 54, S79-S82
- Shinozaki, Y., Furuichi, K., Toyama, T., Kitajima, S., Hara, A., Iwata, Y., Sakai, N., Shimizu, M., Kaneko, S., Isozumi, N., Nagamori, S., Kanai, Y., Sugiura, T.,



- Kato, Y., dan Wada, T. 2017. Impairment of the carnitine/organic cation transporter 1-ergothioneine axis is mediated by intestinal transporter dysfunction in chronic kidney disease. *Kidney Int.*, 92(6), 1356-1369
- Song, T.Y., Lin, H.C., Chen, C.L., Wu, J.H., Liao, J.W., dan Hu, M.L. 2014. Ergothioneine and melatonin attenuate oxidative stress and protect against learning and memory deficits in C57BL/6J mice treated with D-galactose. *Free Radic Res.*, 48(9), 1049-60
- Yoshida, S., Shime, H., Matsumoto, M., Kasahara, M., dan Seya, T. 2019. Anti-oxidative amino acid L-ergothioneine modulates the tumor microenvironment to facilitate adjuvant vaccine immunotherapy. *Front Immunol.*,10, 671

## 1b.4. Submit Awal

The screenshot shows a Gmail interface on a Windows desktop. The browser address bar shows the URL: `mail.google.com/mail/u/0/?q=JTEP#starred/FMfcgzGsmhcKkfHQQmZzFDFQXsBfnGV`. The search bar contains `is:starred`. The left sidebar shows the Gmail navigation menu with 'Starred' selected. The main content area displays an email from 'Dr. Ir. Agus Haryanto, MP' (egusharyid65@gmail.com) received on Tuesday, May 23, 10:53 AM. The email subject is '[JTEP-L] Journal Registration' and is marked as 'External' and 'Inbox'. The email body contains the following text:

You have now been registered as a user with Jurnal Teknik Pertanian Lampung (Journal of Agricultural Engineering). We have included your username and password in this email, which are needed for all work with this journal through its website. At any point, you can ask to be removed from the journal's list of users by contacting me.

Username: haris  
Password: 230366

Thank you,  
Dr. Ir. Agus Haryanto, MP

Jurnal Teknik Pertanian  
<http://jurnal.fp.unila.ac.id/index.php/JTP>  
email: [jurnal.tep@fp.unila.ac.id](mailto:jurnal.tep@fp.unila.ac.id) or [ae.journal@yahoo.com](mailto:ae.journal@yahoo.com)

An 'Activate Windows' watermark is visible at the bottom right of the email content.

The Windows taskbar at the bottom shows the search bar, taskbar icons for a dragon, Word, and Chrome, and the system tray with the date 10/16/2023 and time 3:54 PM.

## 1b.5. Editor Decision

The screenshot shows a Gmail interface on a Windows desktop. The browser tabs include "[JTEP-L] Editor Decision", "Active Submissions", "PKP User Home", and "Vol 12, No 4 (2023)". The address bar shows a Gmail URL. The left sidebar contains navigation options: Mail (99+), Compose, Chat, Spaces, and Meet. The main inbox area shows a list of folders: Inbox (641), Starred, Snoozed, Sent, Drafts (8), and More. A search bar at the top contains "is:starred". The selected email is from Agus Haryanto (agus.haryanto@fp.unila.ac.id) via sendinblue, dated Tuesday, July 18, 2:18 PM. The email content is as follows:

Helmi Haris:

We have reached a decision regarding your submission to Jurnal Teknik Pertanian Lampung (Journal of Agricultural Engineering), "Exploration of Oyster Mushrooms for Functional Fresh Food".

Our decision is to: RESUBMIT for review

To make it easier for the next steps, please use a RED FONTS in responding to comments of REVIEWER A and BLUE FONTS for REVIEWER B's. The responses for both reviewers should be combined in one file.

The revised manuscripts should be re-uploaded to OJS JTEP in the section of EDITOR DECISION -> Author Version.

Revised manuscript MUST be uploaded within 14 days. If there is no progress within that time, your manuscript will be REJECTED.

Thank you for considering JTEP as the venue for your scientific publication.

At the bottom of the email, there is a watermark for "Windows" and a message: "Go to Settings to activate Windows."

The Windows taskbar at the bottom shows the search bar, task view, and system tray with the date and time: 4:45 PM, 10/16/2023, and temperature: 30°C.

## 1b.6.a. Hasil Review dan Revisi dari Reviewer 1

### HASIL REVIEW DARI REVIEWER 1 :

#### Exploration of Oyster Mushrooms for Functional Fresh Food

Commented [u1]: The title does not match the contents of the manuscript

**Abstract.** This article presents studies on the physicochemical quality of oyster mushrooms grown within a housing and controlled by the Internet of Things (IoT). The goals of this study were to assess (1) the impact of indoor air quality on the growth and quality of mushrooms and (2) the antioxidant content of oyster mushrooms. In this study, the air temperature and humidity per unit mass of oyster mushroom per unit time will be recorded and automatically controlled by an IoT system. Additionally, their physicochemical and microbiological quality were evaluated using physico-analytical instruments, and the potency of their ergothioneine (EGT) content was investigated using the HPLC method. The temperature of the air inside was between 29 and 35 degrees Celsius, and the relative humidity was between 60% and 90%. The weight of fresh oyster mushroom was 865 mg. The length, width, and height of the fresh mushroom were measured to be 41.5 mm, 60.0 mm, and 29.5 mm, respectively. The microbiological test confirmed that there was no salmonella infection in the collected mushrooms. The button-stage mushrooms have less total fungus than the bloom-stage mushrooms. The extraction standard method employs an EGT content of 0.674 mg/g as determined by chromatography data analysis. The oyster mushrooms can be consumed as a healthy meal, and the study of EGT showed also very prospective as one of immunotherapeutic food.

Commented [u2]: One sample or more? If the sample is more than one, the average should be presented.

Commented [u3]: One sample or more? If the sample is more than one, the average should be presented

Keywords: ergothioneine, Fibre-reinforced plastic house, Internet of think, oyster mushrooms

#### INTRODUCTION

The oyster mushroom is a type of mushroom that specifically grows in tropical countries such as Indonesia. oyster mushrooms are grown on aggregate media one of them is the paddy waste from the paddy cultivation. Therefore, generally at the rice production centre area mostly becoming the centre for mushrooms production. This can be correlated with the availability of biomass as the main growing media for mushroom.

Commented [u4]: Capital letter!

Cultivating high quality of the mushrooms required high-quality seeds, the high-quality media resources as well as the optimal environment due to the mushrooms are sensitive to climate change. To fulfil the optimum condition for mushrooms cultivation, an adequate production house is required to be implemented by environment controller and high-quality safety materials for growing media and to avoid using industrial in order to produce free contaminant (Kopinski, and Kwiatkowska-Marks, 2012).

A prototype of Fiber Reinforced Plastic (FRP) house (Ridwan Rachmat and Horibe, 1999) is a proper construction for mushroom production housing, and it is implemented with an Internet of things (IoT) based connected to various devices microcontroller. The mushroom production house used IoT control system is to make it easier to monitor the air condition inside the house online by mean of displaying the value generated from the installed sensors inside the house. According to Shasha Asyarita & Ani Lestari [7], temperature and humidity in production house of mushrooms greatly affect the growth process of mushrooms. So that the mushrooms do not rot, brown and wilt, the humidity in the mushroom production house should not be too high or low, ranging from 75%-90% at the humidity level of the mushroom production house.

Research by Dhiya et al [5] who conducted an analysis of the efficiency of the edible mushroom stated that the growth of high consumption of mushrooms was due to the high protein content of edible mushrooms. The mushroom has good properties for the nutritional needs of the human body such as being rich in protein, vitamin C and various water-soluble vitamins (riboflavin, biotin and thiamine), fat (5.7%), carbohydrates (56,8%), amino acids, unsaturated fats, essential minerals (sodium, potassium and phosphorus) and has a low calorific value [6].

Mushrooms contain various types of nutrients those are beneficial to the health of the human body, such as carbohydrates, proteins, and fats. Several types of essential nutrients found in edible mushrooms include amino acids (glutamic acid, proline, phenylalanine, lysine, histidine, etc.), fatty acids (lauric, palmitic, oleic, lenoleic, etc.), potassium, calcium, and phosphorus (Adiandri et al., 2018). One type of essential amino acid found in mushrooms is ergothioneine (EGT). EGT is a derivative of histidine which contains functional groups of sulfur atoms and hydrogen atoms (-SH) and it can only be synthesized by fungi and actinobacteria (Borodina et al., 2020; Halliwell et al., 2018).

Mushrooms as a food source have been reported to have the highest level of ergothioneine compared to any other food source (Dubost et al., 2006, Dubost et al., 2007). In an early report, it has been shown that if we consume mushrooms as our regular food, the bioavailability of ergothioneine remains in our body (Weigand-Heller et al., 2012). The ergothioneine chemical compound is accumulated in the fruiting bodies as well as in the mycelia of the mushroom (Borodina et al., 2019, Kalaras et al., 2020). Several studies have been conducted with samples of mushrooms to describe improved ergothioneine production by the addition of several additives, such as aspartic acid, lysine, and methionine, which demonstrate increased ergothioneine biosynthesis (Lee et al., 2009). In addition, it has also been described that the production of ergothioneine increases with increased pH and is higher under alkaline conditions (Huang et al., 2015).

Research on the identification and isolation of EGT from several fungal varieties has been carried out. The content of EGT in mushrooms is quite high and has good antioxidant activity. In addition, differences in genus and species of fungi have different chemical compositions contained in them so that it affects the proportion of EGT in mushrooms (Kalaras et al., 2017). The results of the literature study indicate that the identification and isolation of EGT from edible mushroom has never been done. Therefore, research to explore the opportunity to use edible mushroom as a source of EGT needs to be done.

The provision of production house that meets food safety requirements is absolutely necessary to produce safe oyster mushrooms for consumption. Meanwhile the technology development of this mushroom production that meets food safety standards for the isolation of ergothioneine as an antioxidant is a potential matter in exploration of mushroom is still limited. This paper describes the research results of the prototype of FRP house with the air condition variation inside the house and the effect of air condition against mushroom quality. The effect of the IoT implementation in controlling the air condition system as well as minimizing the human contact during oyster mushroom growing during cultivation periods, and to explore the value added of mushroom through the ergothioneine (EGT) analysis as the of antioxidant content in mushroom.

## MATERIAL AND METHODS

The scope of research includes (1) constructing a prototype of FRP house with IoT control system for oyster mushroom cultivation; (2) to evaluate the air condition variation inside

the house and the effect of air condition against mushroom growth and quality; (3) Analysis of antioxidant content in mushroom. The materials and chemicals used in this research are analytical grade chemicals. The effectiveness of antioxidant properties on isolated EGT was measured by in vitro method.

**FRP House**

The FRP house built in a prototype scale (Figure 1) at an area of 650 cm x 350 cm with a light steel alloy as the frames and the roof is covered by a thin metal sheet and all the wall blanketed by fibre reinforced plastic (FRP), and white tile's floor, there are two shelves at inside the FRP house with two racks of 400 cm length and 100 cm width respectively.

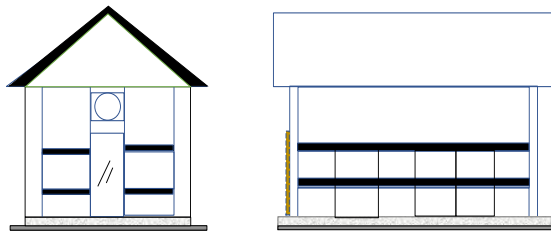

Figure 1. Prototype of FRP house model of straw mushroom

The FRP House implemented with an Internet of Think (IoT) system (Figure 2) to actuate a set of devices to measure the parameters of air temperature, air humidity, moisture content of the media. The control devices are 30 nozzles of mist sprayer setup along the rack of shelves above the media which are connected with a special hose. Hot air temperatures above 35°C, caused the exhaust fan is on, whenever a drastic drop of air temperature inside the FRP house below 29°C, thus the heater mixer will operate automatically to increase the room temperature. The controller specification showed in Table 1 are set at day and night time with the elapsed time of intervals are enable to monitor the parameters conditions to avoid disturbance during mushrooms growth.

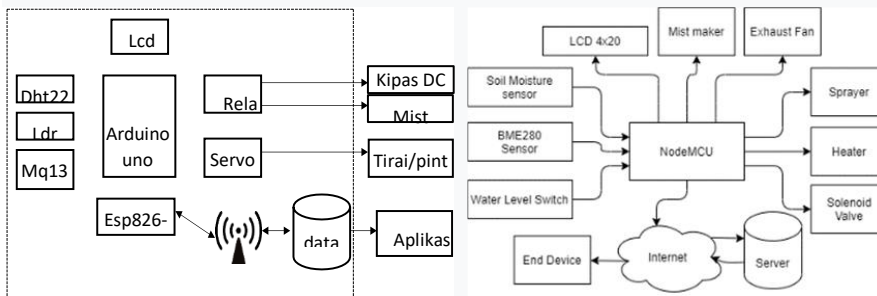

Figure 2. Architecture of IoT of production house in oyster mushroom

**Commented [u5]:** Move it to background!  
**Commented [u6]:** Mention in full!  
**Commented [u7]:** List all materials and equipment used in this section!

**Commented [u8]:** Make some effective sentences!

**Commented [u9]:** Recheck!

**Commented [u10]:** What's the difference between the two pictures? explain the picture right and left! Right and left images merge and display in a clear view!

The Arduino Node MCU is an open-source platform based on IoT, which is able to implement various commands with programming languages. The application of the C programming language uses a sketch on the Arduino IDE (Integrated Development Environment), which is capable of programming various kinds of microcontrollers including Node MCU. The Node MCU has a small size compared to Arduino UNO, by using the ESP8266 module, there are GPIO (General-purpose input/output), PWM (Pulse Width Modulation), I2C, UART (Universal Asynchronous Receiver Transmitter), 1-Wire and ADC (Analog) to Digital Converter).

Commented [u11]: Recheck!

Tabel 1. Component and specification of control system.

Component	Specifications
Sensor BME280	Air temperature and Humidity sensor
Soil Moisture sensor	Soil moisture content controller
Water Level sensor	Water height controller
Mist-maker	Fog production and controller
Exhaust fan	Air humidity controller
Arduino IDE 1.8.9, Fritzing	temperature and Humidity

Commented [u12]: Correct use of capital letters!

### Cultivation Process Procedure

Mushroom cultivation process procedure was carried out inside FRP House and utilized the organic components which are mixed and fermentation process for 4 days to be a compost, and then fill into bag log evenly in a plastic sacks assembled inside FRP House. The layers of compost were pasteurized inside FRP house with closed cover condition tightly and then fogging with hot air at temperature 60-65°C for 8 hours. The mushroom seeds were inside over the bag logs of compost and then to be incubated for 3 days at around 29-30°C of inside air temperature. The treatment during mushroom growth up to harvest periods comprised of the inside air temperature, humidity and soil water content.

### Extraction of the Active Compound Ergothioneine

The isolation of ergothioneine EGT compounds from the harvested fresh mushrooms was carried out by the extraction method refers to the method developed by Ito et al. (2011) and Nguyen et al. (2012) with some modifications. Pre-treatment (blanching and non-blanching), mushroom before drying methods by electric oven drying.

The experimental factors of extraction employed the temperature 40°C and 60°C respectively with the variation of the extraction solvent (water and ethanol 30% (v/v), 50% (v/v), 70% ethanol (v/v), and ethanol 100 % (v/v)). The extraction procedure utilized 10 grams of dry mushroom powder and 200 mL of solvent which has been heated in a shaking water bath according to variations in temperature. The solvent along with the solute was continuously agitated at 100 rpm for 1 hour, then cooled at room temperature for 2 hours. Then it was centrifuged at 600 rpm for 15 minutes at 25°C. The achieved of the process is supernatant which was transferred to a conical tube for further evaporation using a vacuum evaporator at a temperature of 40°C to evaporate the remaining solvent up to be a paste of EGT extract. Furthermore, the paste of EGT was dried by the freeze-drying method. The dried EGT sample was then weighed to measure as the extraction yield.

### EGT concentration analysis

Analysis of the concentration of EGT in the oyster mushroom extract used the HPLC method referring to the method used by Kalaras et al. (2017) with some modifications. The mushroom powder (0.5 g) and 7 ml of ethanolic was put into a 15 ml centrifuge tube (consisting of 10 mM dithiothreitol, 100 M betaine, 100 M 2-mercapto-1-methyl imidazole) and 3 ml of distilled water was added and homogenized with a vortex for 10 seconds. A total of 2 mL of 1% SDS solution dissolved in ethanol was added and homogenized with a vortex for 10 seconds. Then the suspension was centrifuged for 20 minutes at 4000 rpm and 25°C. The supernatant formed was transferred to a 15 mL centrifugation tube. Then, 1 mL of the supernatant was put into a micro tube and allowed to stand for 24 hours. The solid formed from this process is then dissolved into 0.5 mL of aqua bides and homogenized using a vortex until it dissolves completely. Samples that have been stored in micro-tubes were centrifuged at 10,000 rpm for 1 minute. The supernatant formed was then filtered using a syringe filter (0.45 100 m) and put into a glass vial for HPLC analysis.

HPLC analysis was performed using column C18. The volume of the solution injected was 10 µL. The mobile phases used mobile phase A (3% acetonitrile, 0.1% TEA, 50 mM dibasic sodium phosphate dissolved in distilled water), mobile phase B (acetonitrile), and mobile phase C (water). The separation was performed on the elution gradient as follows: 0 minutes 15:85 (B:C), 0-5 minutes set at a slope of 5:15:85 (A:B:C), 5-6 minutes set at a slope of 10:90 (B:C), 6-8 minutes at 3:97 (B:C), and 8-15 at 3:97 (B:C). EGT was detected at a wavelength of 254 nm with a peak retention time of 5.7 min which was quantified using an external standard curve.

The antioxidant activity of EGT from edible mushroom was carried out by measuring the radical scavenging activity of DPPH referring to the method of Pahila et al. (2019). The analytical procedure comprised of 50 L of straw mushroom extract is added to 50 L of DPPH solution (100 M in 85% ethanol) and stirred using a vortex. After 15 minutes, the solution mixture was put into a 50 L Pyrex NMR capillary tube, then the DPPH radical spin resonance was measured with a spectrometer at a wavelength of 517. The spectrometer settings as microwave power, 1.2 mW; microwave frequency 9149.3 MHz; field magnet, 325.5 25 mT; and the sweep time, 30 seconds. Various concentrations of EGT were measured for resonance to construct a standard curve. The radical scavenging activity of DPPH was expressed as mmol equivalent of EGT per mL of sample.

## RESULTS AND DISCUSSION

### FRP House

The prototype of the FRP house is shown in Figure 3. Condition of the air temperature, air humidity and water content of the media inside the FRP house during mushroom cultivation are monitored automatically. The variation of air temperature around 29-39°C is relatively stable, while condition at day, night and rainy, resulted in high fluctuated of air humidity 40-98% with the water content of the media around 39-99%.

The devices inside the mushroom's FRP house consists of circuits, input blocks and output blocks which are joint by the Nodemcu microcomputer to control the air condition inside mushroom's FRP house. The input block is a soil moisture sensor and BME280 as a temperature, humidity and barometric detector. The sensor will generate an input value for the



Nodemcu microcomputer, this value will be processed by Nodemcu which produces an output value to the connected devices. While the output block is a receiver a value generates by sensor through Nodemcu, such as a heater will operate if the temperature inside the mushroom's FRP house is low and the mist-maker will turn off if the humidity inside the mushroom's FRP house is sufficient. Nodemcu has a Wi-Fi module that is able to save the values and data in the database, this can make it easier to use a smartphone to access mushroom's FRP house condition even the values or data remotely. The IoT control system is setup for operating the hot air exhaust with the mist sprayer process taking place in parallel if the air temperature at above 39°C with humidity below 60%. And when the opposite condition occurred (below 29°C), thus the water heater will actively operate spraying hot air vapor into the FRP House. This methods of IoT control mechanism will reduce the human intervention so that the growth process of mycelium and pinhead of fungal embryos can achieve optimally.

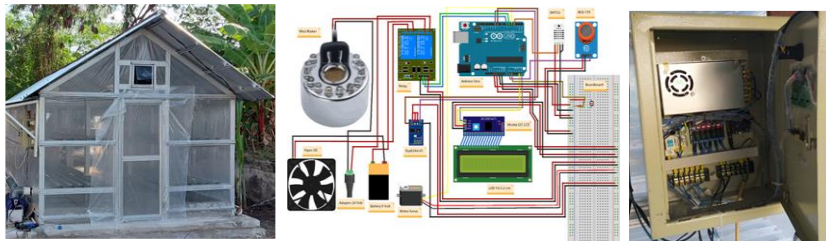

Figure 3. The prototype of the FRP house with IoT circuit

Commented [u13]: Describe each image

The generated measuring instrument and sensors performance corresponded the proposed elapsed time through the interface to display's monitor. In table 2 showed the comparison of sensor values with measuring instruments. Digital measuring instrument used to compare sensor values such as Hygrometer, lux meter and the average temperature difference of 0.7°C and humidity of 2.1%.

Table 2. Temperature and humidity sensor testing

Temperature			Humidity		
Sensor	Device	Diff	Sensor	Device	Diff
31.7	30.8	0.9	77	76	1
31.6	30.7	0.9	78.3	77	1.3
31.7	30.7	1	78.9	78	0.9
31.8	30.7	1.1	78.3	78	0.3
31.8	30.7	1.1	79.1	79	0.1
31.8	31.3	0.5	80.2	79	1.2
32.2	31.1	1.1	83.4	82	1.4
32.2	31.2	1	82	82	0
32.1	31.5	0.6	81.3	81	0.3
32.1	31.1	1	81.2	81	0.2

Table 3 is a comparison graph of sensor values with measuring instruments. Digital measuring tools used to compare sensor values such as mini-Hygrometer, lux meter and carbon

detector. The test was carried out by taking samples 30 times by getting an average temperature difference of 0.91  $^{\circ}\text{C}$ , humidity 0.89%. Furthermore, the light sensor gets an average difference of 19.76% and gas content of 10.13 ppm. The second test evaluates the performance of the tool and obtains an accuracy rate of success of 93.3%.

Commented [u14]: Recheck!

Table 3. Light sensor and CO<sub>2</sub> content

light			Gas Content		
Sensor	Device	Diff	Sensor	Device	Diff
192	175	17	21	10	11
187	144	43	33	12	21
182	152	30	16	9	7
103	100	3	24	16	8
170	145	25	22	20	2
-	-	-	-	-	-
-	-	-	-	-	-
144	124	20	18	7	11
169	123	46	10	3	7
118	115	3	15	8	7
124	121	3	24	16	8
128	122	6	30	20	10

### Effect of FRP House to Mushroom quality

Air conditions and lighting inside mushroom's FRP house day and night during the mushroom growth (Figure 4) contribute for the effect to the quality of harvested fresh mushroom. The results of quality analysis indicated that the range of phenotype length of 2.5-10 cm, diameter of 3-10 cm and weight 10-120 gram (Figure 5), in general the mushrooms growth from organic media are longer and heavier than non-organic growth media with more uniform dimensions except for the diameter of phenotype.



Commented [u15]: In English! complete the unit!

Figure 4. Condition of air temperature, RH, and moisture content inside FRP House



Figure 5. Dimension of harvested oyster mushroom

The hardness test per fruit and the moisture content of the mushrooms were carried out by comparing the mushrooms on organic media and non-organic media on the FRP house with the housing at the farm level as shown in Table 4, indicating that the mushrooms in the model FRP house were harder and less water content than that ones in the farmer mushroom's housing at the farm level.

Commented [u16]: Make some effective sentences!

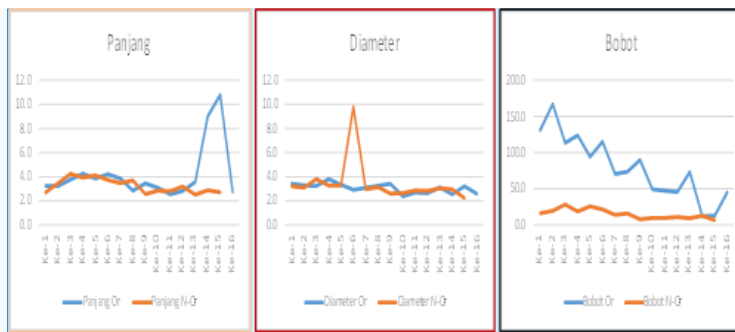

Figure 6 Dimension of fresh harvested mushroom

Commented [u17]: In English! And clarify the image resolution!

Table 4. Characteristics of straw mushroom

No	Parameter	average
1.	texture	865,0±100,0
2	Dimension	
	- Length (mm)	41,5±6,0
	- Width (mm)	60,0±4,0
	- Height (mm)	29,5±9,0

### Micro Laboratory Analysis

The results of micro-laboratory analysis (Table 6) showed that the fresh harvested mushroom are negative from total fungus and salmonella

Commented [u18]: Recheck!

Tabel 5. Analysis result of total fungus and salmonella

Code	Phase of fungus	Total fungus (cfu/g)	Salmonella (negative/25g)
A	Non organic mushroom, Bloom	2.9x10 <sup>5</sup>	negative
B	Non organic mushroom, fresh	1.0x10 <sup>5</sup>	negative
C	Organic mushroom, bloom	3.5x10 <sup>4</sup>	negative
D	Organic mushroom, fresh	6.5x10 <sup>4</sup>	negative
E	non organic mushroom, bloom	1.7x10 <sup>6</sup>	negative
F	non organic, mushroom, fresh	5.4x10 <sup>4</sup>	negative

### Extraction of the Active Compound Ergothioneine

The results of the analysis on functional compounds of EGT in oyster mushrooms using the HPLC method, a graphic recording of the results of HPLC analysis of dried mushrooms with standard ethanol solvent. The average recording results from the EGT chromatography results were 0.674 mg/g as shown in Table 6

Table 6. Results of chromatogram graphic data processing from mushroom extract

Code	Area	Intercept	Slope	V (ml)	fp	B.s (g)	C (ppm)	C (%)	mg/g DW
Organic, et 70%	2,005	0,1501	0,0643	20	250	0,2006	719032,64	71,90	0,799
	2,0309	0,1501	0,0643	20	250	0,2006	729072,50	72,91	0,810
Non organic, et 70%	2,2289	0,1501	0,0643	20	250	0,2688	601370,99	60,14	0,668
	2,2626	0,1501	0,0643	20	250	0,2688	611119,98	61,11	0,679
Ethanol 96%	2,2255	0,1501	0,0643	20	250	0,2034	793432,33	79,34	0,882
	2,0676	0,1501	0,0643	20	250	0,2034	733066,64	73,31	0,815
Powder, organic	1,3702	0,1501	0,0643	20	250	0,2022	469216,53	46,92	0,521
	1,3862	0,1501	0,0643	20	250	0,2022	475369,69	47,54	0,528
Powder, anorganic	1,3431	0,1501	0,0643	20	250	0,2009	461763,43	46,18	0,513
	1,2709	0,1501	0,0643	20	250	0,2009	433817,65	43,38	0,482

The extraction process breaks down the bonds among the molecules of the material so that EGT and phenol compounds are produced with varying concentrations depending on the type of solvent used (Table 7). The results of the standard solution analysis showed that the

EGT compound had a retention time of  $3.33 \pm 0.06$  minutes, while the mushroom sample showed a retention time of 3.28 to 3.30 minutes.

Table 7. Recapitulation of EGT characterization data from edible mushrooms

Solvent	Concentration EGT (mg/g DW)	Total Phenol (mg/g DW)
Ethanol 96%	$0,805 \pm 0.01$	$0,015 \pm 0.00$
Ethanol 70%	$0,848 \pm 0.05$	$0,025 \pm 0.00$

The extraction process using 70% ethanol produced higher concentrations of EGT and phenol than the extraction process using 96% ethanol. This shows that 70% of ethanol solvent is more effective used to bind EGT and phenol compounds in oyster mushrooms than that in pure solvents. This result is in line with the previous study conducted by Nguyen et al. (2012). The process of extracting the *Flammulina velutipes* mushroom using 70% ethanol was able to produce EGT and phenol compounds with higher concentrations than that the extraction using 50% and 100% of ethanol, with values of  $2.05 \pm 0.18$  mg/g and  $3.65 \pm 0,08$  DW, consecutively.

The extraction process that has been carried out can break down the bonds between the molecules of the material so that EGT and phenol compounds are produced with varying concentrations depending on the type of solvent used (Table 8). The results of the standard solution analysis showed that the EGT compound had a retention time of  $3.33 \pm 0.06$  minutes, while the straw mushroom sample showed a retention time of 3.28 to 3.30 minutes.

Table 8. Methods and varying concentrations type of solvent for EGT

Species of mushroom	Methods	Concentration Ergothioneine (mg/g BK)
<i>Flammulina velutipes</i> Ref.: Nguyen et al. (2012)	water	$1.50 \pm 0.21$
	Ethanol 70%	$2.05 \pm 0.18$
	Methanol 70%	$1.86 \pm 0.04$
	Acetone 70%	$1.92 \pm 0.07$
<i>Pleurotus eryngii</i>	Hot water	0.86
<i>Pleurotus citrinopileatus</i>	Ref.: Yen et al. (2018)	3.73
<b>Oyster Mushroom</b>	<b>Ethanol 70%</b>	<b><math>0.67 \pm 0.01</math></b>

Commented [u19]: Correct capitalization!

The extraction process for active compounds (Table 9), such as EGT and phenol, is influenced by several factors, such as solvent polarity and process conditions. A mixture of solutions has the ability to bind the active compound better than the pure solvent. This is due to the mixing of nonpolar solvents with water which can increase the polarity index of the solvent so that the extraction efficiency increases.

In addition, the increase in extraction temperature was positively correlated to the increase in antioxidant activity and polyphenols (flavonoids and total phenol), while the

increase in extraction time was not positively correlated to the increase in antioxidant activity and polyphenols. In addition, the presence of agitation during the extraction process also contributes to increasing the extraction yield. This happens because the agitation process can increase the rate of diffusion and minimize the barriers to mass transfer from the solid surface into the solution (Muhamad et al., 2014).

Table 9. the results of chromatograph analysis of mushroom samples

Code	Area	V (ml)	fp	B.s (g)	C (ppm)	C (%)
Organic	2,005	20	250	0,20	719032,6	71,90
Non organic	2,2289	20	250	0,27	601371,0	60,14
Ethanol 96%	2,2255	20	250	0,20	793432,3	79,34
Flour (organic)	1,3702	20	250	0,20	469216,5	46,92
Flour (unorganic)	1,3431	20	250	0,20	461763,4	46,18

Commented [u20]: Recheck!

Table 10 showed that the role in synthesizing EGT is the methyltransferase enzyme which is encoded by the EGT gene and specifically remodels histidine into EGT compounds (Stampfli et al., 2020). The results of another study stated that the biosynthesis of EGT is a complex synthesis process involving various types of amino acids and carbon sources. However, in principle there are three types of amino acids that play an important role in EGT biosynthesis, namely methionine, histidine, and cysteine. Histidine acts as a starting material that plays a role in the whole series of EGT biosynthesis. Cysteine serves to provide a source of sulfur atoms, while methionine which contains the protein S-adenosyl-l-methionine (SAM) acts as a precursor in reactions involving methyl groups. In supporting its growth, cells can use dextrose, fructose, glycerol, maltose, and sucrose as carbon sources. A suitable carbon source for EGT biosynthesis is glycerol because it is able to maintain cells in a longer stationary growth phase. In the glycolysis cycle, glycerol is broken down into glycerol-3 phosphate by the enzyme glycerol kinase. Furthermore, glycerol-3 phosphate is broken down by the enzyme glyceraldehyde-3 phosphate dehydrogenase to glyceron-P which is then overhauled by triosephosphate isomerase to glyceraldehyde 3 phosphate (GAP). GAP acts as a precursor in the glycolysis process to produce pyruvic acid which will also be a substrate in the Krebs cycle. Consumption of large amounts of pyruvic acid can stimulate enzymatic reactions of amino acids to produce EGT (Yu et al., 2020).

Table 10. Concentration of ergothioneine in different species of mushroom.

Mushroom Species	Ergothioneine Content*	Mushroom Species	Ergothioneine Content*
<i>Fomitopsis pinicola</i>	0.07 ± 0.01	<i>Polyozellus multiplex</i>	0.51 ± 0.01
<i>Ganoderma applanatum</i>	0.06 ± 0.02	<i>Ramaria botrytis</i>	0.29 ± 0.03
<i>G. lucidum</i>	0.08 ± 0.02	<i>S. granulatus</i>	0.09 ± 0.03

Commented [u21]: Note the writing of the Latin name

Mushroom Species	Ergothioneine Content*	Mushroom Species	Ergothioneine Content*
<i>G. neo-japonicum</i>	0.07 ± 0.00	Lampteromyces japonicus	0.43 ± 0.16

\*mg/g dw; Mean ± SD.

Sources: Modified from [Lee et al., 2009](#), [Ito et al., 2011](#).

Commented [u22]: Fix reference writing!

### CONCLUSION

The research results showed that the cultivation of oyster mushroom with a kumbung with ceramic floors and plastic walls and an IoT management. The temperature of the air inside was between 29 and 35 degrees Celsius, and the relative humidity was between 60% and 90%. The weight of fresh oyster mushroom was 865 mg. The length, width, and height of the fresh mushroom were measured to be 41.5 mm, 60.0 mm, and 29.5 mm, respectively. The microbiological test confirmed that there was no salmonella infection in the collected mushrooms. The stage of mushrooms have less total fungus than the bloom-stage mushrooms. The extraction standard method employs an EGT content of 0.674 mg/g as determined by chromatography data analysis. The oyster mushrooms can be consumed as a healthy meal, and the study of EGT showed also very prospective as one of immunotherapeutic food.

Commented [u23]: Recheck!

Commented [u24]: Average may be?

### REFERENCES

- Adiandri, R.S., Hidayah, N., dan Nugraha, S. 2018. Identification of amino acid, fatty acid, mineral content and respiration rate of straw mushroom in different stage of maturity. Proceeding the international seminar on tropical horticulture, 239-248
- Borodina, I., Kenny, L.C., McCarthy, C.M., Paramasivan, K., Pretorius, E., Roberts, T.J., van der Hoek, S.A, dan Kell, D.B. 2020. The biology of ergothioneine, an antioxidant nutraceutical. Nutrition Research Review, 33, 190-217
- Cheah, I.K., dan Halliwell, B. 2020. Could ergothioneine aid in the treatment of coronavirus patients? Antioxidants, 9, 595
- Dhalsamant, K., Dash, S.K., Bal, L.M., dan Panda, M.K. 2015. Effect of perforation mediated MAP on shelf life of mushroom (*Volvariella volvacea*). Scientia Horticulturae, 189, 41-50
- Halliwell, B., Cheah, I.K., dan Tang, R.M.Y. 2018. Ergothioneine – a diet-derived antioxidant with therapeutic potential. FEBS Letters, 592, 3357-3366
- Ito, T., Kato, M., Tsuchida, H., Harada, E., Niwa, T., dan Osawa, T. 2011. Ergothioneine as an anti-oxidative/anti-inflammatory component in several edible mushrooms. Food Sci. Technol. Res., 17(2), 103-110
- Jamjumroon, S., Wongs-Aree, C., McGlasson, W.B., dan Sriloang, V. 2012. Extending the shelf-life of straw mushroom with high carbon dioxide treatment. Journal of Food Agriculture and Environment, 10(1):78-84
- Kalaras, M.D., Richi, J.P., Calcagnotto, A., dan Beelman, R.B. 2017. Mushrooms: a rich source of the antioxidants ergothioneine and glutathione. Food Chemistry, 233, 429-433
- Kopinski, L., dan Kwiatkowska-Marks, S. 2012. Utilization of waste newspaper using oyster mushroom mycelium. Industrial & Engineering Chemistry Research, 51, 4440-4444

- Nguyen, T.H., Nagasaka, R., dan Ohshima, T. 2012. Effects of extraction solvents, cooking precedures and storage conditions on the contents of ergothioneine and phenolic compounds and antioxidative capacity of cultivated mushrooms *Flammulina velutipes*. *International Journal of Food Science & Technology*, doi: 10.1111/j.1365-2621.2012.02959.x
- Nur Sakinah, M.J., Misran, A., Mahmud, T.M.M., Abdullah, S., dan Azhar, M. 2020. Evaluation of storage temperature, packing system and storage duration on postharvest quality of straw mushroom (*Volvariella volvacea*). *Food Research*, 4(3), 679-689
- Pahila, J., Ishikawa, Y., dan Ohshima, T. 2019. Effects of ergothioneine-rich mushroom extract on the oxidative stability of astaxanthin in liposomes. *Journal of Agricultural and Food Chemistry*, 67, 3491-3501
- Repine, J.E., dan Elkins, N.D. 2012. Effect of ergothioneine on acute lung injury and inflammation in cytokine insufflated rats. *Preventive Medicine*, 54, S79-S82
- Shinozaki, Y., Furuichi, K., Toyama, T., Kitajima, S., Hara, A., Iwata, Y., Sakai, N., Shimizu, M., Kaneko, S., Isozumi, N., Nagamori, S., Kanai, Y., Sugiura, T., Kato, Y., dan Wada, T. 2017. Impairment of the carnitine/organic cation transporter 1-ergothioneine axis is mediated by intestinal transporter dysfunction in chronic kidney disease. *Kidney Int.*, 92(6), 1356-1369
- Song, T.Y., Lin, H.C., Chen, C.L., Wu, J.H., Liao, J.W., dan Hu, M.L. 2014. Ergothioneine and melatonin attenuate oxidative stress and protect against learning and memory deficits in C57BL/6J mice treated with D-galactose. *Free Radic Res.*, 48(9), 1049-60
- Yoshida, S., Shime, H., Matsumoto, M., Kasahara, M., dan Seya, T. 2019. Anti-oxidative amino acid L-ergothioneine modulates the tumor microenvironment to facilitate adjuvant vaccine immunotherapy. *Front Immunol.*, 10, 671



## HASIL REVISI REVIEWER 1 :

### Exploration of Oyster Mushrooms for Functional Fresh Food

**Abstract.** This article presents studies on the physicochemical quality of oyster mushrooms grown within a housing and controlled by the Internet of Things (IoT). The goals of this study were to assess (1) the impact of indoor air quality on the growth and quality of mushrooms and (2) the antioxidant content of oyster mushrooms. In this study, the air temperature and humidity per unit mass of oyster mushroom per unit time will be recorded and automatically controlled by an IoT system. Additionally, their physicochemical and microbiological quality were evaluated using physico-analytical instruments, and the potency of their ergothioneine (EGT) content was investigated using the HPLC method. The temperature of the air inside was between 29 and 35 degrees Celsius, and the relative humidity was between 60% and 90%. The average weight of select fresh oyster mushrooms was 865 mg. The average length, width, and height of the fresh mushroom were measured to be 41.5 mm, 60.0 mm, and 29.5 mm, respectively. The microbiological test confirmed that there was no salmonella infection in the collected mushrooms. The button-stage mushrooms have less total fungus than the bloom-stage mushrooms. The extraction standard method employs an EGT content of 0.674 mg/g as determined by chromatography data analysis. The oyster mushrooms can be consumed as a healthy meal, and the study of EGT showed also very prospective as one of immunotherapeutic food.

Keywords: ergothioneine, Fibre-reinforced plastic house, Internet of think, oyster mushrooms

#### INTRODUCTION

The oyster mushroom is a type of mushroom that specifically grows in tropical countries such as Indonesia. Oyster mushrooms are grown on aggregate media one of them is the paddy waste from the paddy cultivation. Therefore, generally at the rice production centre area mostly becoming the centre for mushrooms production. This can be correlated with the availability of biomass as the main growing media for mushroom.

Cultivating high quality of the mushrooms required high-quality seeds, the high-quality media resources as well as the optimal environment due to the mushrooms are sensitive to climate change. To fulfil the optimum condition for mushrooms cultivation, an adequate production house is required to be implemented by environment controller and high-quality safety materials for growing media and to avoid using industrial in order to produce free contaminant (Kopinski, and Kwiatkowska-Marks, 2012).

A prototype of Fiber Reinforced Plastic (FRP) house (Ridwan Rachmat and Horibe, 1999) is a proper construction for mushroom production housing, and it is implemented with an Internet of things (IoT) based connected to various devices microcontroller. The mushroom production house used IoT control system is to make it easier to monitor the air condition inside the house online by mean of displaying the value generated from the installed sensors inside the house. According to Shasha Asyarita & Ani Lestari [7], temperature and humidity in production house of mushrooms greatly affect the growth process of mushrooms. So that the mushrooms do not rot, brown and wilt, the humidity in the mushroom production house should not be too high or low, ranging from 75%-90% at the humidity level of the mushroom production house.

Research by Dhiya et al [5] who conducted an analysis of the efficiency of the edible mushroom stated that the growth of high consumption of mushrooms was due to the high protein content of edible mushrooms. The mushroom has good properties for the nutritional needs of the human body such as being rich in protein, vitamin C and various water-soluble

**Commented [u25]:** The title does not match the contents of the manuscript

**Commented [B626R25]:** !PHYSICOCHEMICAL QUALITY OF OYSTER MUSHROOMS FOR FUNCTIONAL FOOD

**Commented [u27]:** One sample or more? If the sample is more than one, the average should be presented.

**Commented [B628R27]:** We used more than one, then the sentence revised: The average weight of selected fresh oyster mushrooms was 865 mg. The average length, width, and height of the fresh mushroom were measured to be 41.5 mm, 60.0 mm, and 29.5 mm, respectively

**Commented [u29]:** One sample or more? If the sample is more than one, the average should be presented

**Commented [u30]:** Capital letter!

**Commented [B631R30]:** Oyster

vitamins (riboflavin, biotin and thiamine), fat (5.7%), carbohydrates (56.8%), amino acids, unsaturated fats, essential minerals (sodium, potassium and phosphorus) and has a low calorific value [6].

Mushrooms contain various types of nutrients those are beneficial to the health of the human body, such as carbohydrates, proteins, and fats. Several types of essential nutrients found in edible mushrooms include amino acids (glutamic acid, proline, phenylalanine, lysine, histidine, etc.), fatty acids (lauric, palmitic, oleic, lenoleic, etc.), potassium, calcium, and phosphorus (Adiandri et al., 2018). One type of essential amino acid found in mushrooms is ergothioneine (EGT). EGT is a derivative of histidine which contains functional groups of sulfur atoms and hydrogen atoms (-SH) and it can only be synthesized by fungi and actinobacteria (Borodina et al., 2020; Halliwell et al., 2018).

Mushrooms as a food source have been reported to have the highest level of ergothioneine compared to any other food source (Dubost et al., 2006, Dubost et al., 2007). In an early report, it has been shown that if we consume mushrooms as our regular food, the bioavailability of ergothioneine remains in our body (Weigand-Heller et al., 2012). The ergothioneine chemical compound is accumulated in the fruiting bodies as well as in the mycelia of the mushroom (Borodina et al., 2019, Kalaras et al., 2020). Several studies have been conducted with samples of mushrooms to describe improved ergothioneine production by the addition of several additives, such as aspartic acid, lysine, and methionine, which demonstrate increased ergothioneine biosynthesis (Lee et al., 2009). In addition, it has also been described that the production of ergothioneine increases with increased pH and is higher under alkaline conditions (Huang et al., 2015).

Research on the identification and isolation of EGT from several fungal varieties has been carried out. The content of EGT in mushrooms is quite high and has good antioxidant activity. In addition, differences in genus and species of fungi have different chemical compositions contained in them so that it affects the proportion of EGT in mushrooms (Kalaras et al., 2017). The results of the literature study indicate that the identification and isolation of EGT from edible mushroom has never been done. Therefore, research to explore the opportunity to use edible mushroom as a source of EGT needs to be done.

The provision of production house that meets food safety requirements is absolutely necessary to produce safe oyster mushrooms for consumption. Meanwhile the technology development of this mushroom production that meets food safety standards for the isolation of ergothioneine as an antioxidant is a potential matter in exploration of mushroom is still limited. This paper describes the research results of the prototype of FRP house with the air condition variation inside the house and the effect of air condition against mushroom quality. The effect of the IoT implementation in controlling the air condition system as well as minimizing the human contact during oyster mushroom growing during cultivation periods, and to explore the value added of mushroom through the ergothioneine (EGT) analysis as the of antioxidant content in mushroom.

The scope of research includes (1) constructing a prototype of FRP house with IoT control system for oyster mushroom cultivation; (2) to evaluate the air condition variation inside the house and the effect of air condition against mushroom growth and quality; (3) Analysis of antioxidant content in mushroom.

## MATERIAL AND METHODS

The materials and chemicals used in this research are analytical grade chemicals. The effectiveness of antioxidant properties on isolated EGT was measured by in vitro method.

**Commented [u32]:** Move it to background!

**Commented [B633R32]:** All right, we moved to the last paragraph of the background

**Commented [u34]:** Mention in full!

**Commented [u35]:** List all materials and equipment used in this section!

### FRP House

The FRP house constructed ~~built in a prototype scale~~ (Figure 1) at an area of 650 cm x 350 cm with a light steel alloy ~~as the~~ frames and ~~the roof is~~ covered by a thin metal sheet roof and ~~all each the~~ wall blanketed by fibre reinforced plastic. (FRP), and white ~~ceramic tile's~~ floor. There are two shelves at inside ~~the FRP house with~~ ~~two racks of~~ 400 cm length and 100 cm width respectively.



Figure 1. Prototype of FRP house model of straw mushroom

The FRP House implemented with an Internet of Think (IoT) system (Figure 2) to actuate a set of devices to measure the parameters of air temperature, air humidity, moisture content of the media. The control devices are 30 nozzles of mist sprayer setup along the rack of shelves above the media which are connected with a special hose. Hot air temperatures above 35°C, caused the exhaust fan is on, whenever a drastic drop of air temperature inside the FRP house below 29°C, thus ~~the heater mixer~~ will operate automatically to increase the room temperature. The controller specification showed in Table 1 are set at day and night time with the elapsed time of intervals are enable to monitor the parameters conditions to avoid disturbance during mushrooms growth.

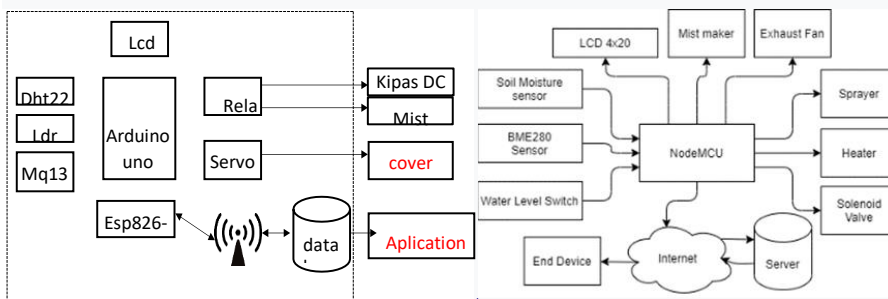

Figure 2. Architecture of IoT of production house in oyster mushroom

Commented [u36]: Make some effective sentences!

Commented [B637R36]: The FRP house constructed ~~built in a prototype scale~~ (Figure 1) on an area of 650 cm x 350 cm with a light steel alloy ~~as the~~ frames and ~~the roof is~~ covered by a thin metal sheet roof and ~~all the each~~ wall blanketed by fibre reinforced plastic. (FRP), and white ~~ceramic tile's~~ floor. There are two shelves at inside ~~the FRP house with~~ ~~two racks of~~ 400 cm length and 100 cm width respectively.

Commented [u38]: Recheck!

Commented [B639R38]: Mixer is omitted

Commented [u40]: What's the difference between the two pictures? explain the picture right and left! Right and left images merge and display in a clear view!

Commented [B641R40]: The right picture explained the network linkages of the block diagram (left)

The Arduino Node MCU is an open-source platform based on IoT, which is able to implement various commands with programming languages. The application of the C programming language uses a sketch on the Arduino IDE (Integrated Development Environment), which is capable of programming various kinds of microcontrollers including Node MCU. The Node MCU has a small size compared to Arduino UNO, by using the ESP8266 module, there are GPIO (General-purpose input/output), PWM (Pulse Width Modulation), I2C, UART (Universal Asynchronous Receiver Transmitter), 1-Wire and ADC (Analog) to Digital Converter).

Commented [u42]: Recheck!

Commented [B643R42]: ADC (Analog to Digital Converter)

Table 1. Component and specification of control system.

Component	Specifications
Sensor BME280	Air temperature and Humidity sensor
Soil Moisture sensor	Soil moisture content controller
Water Level sensor	Water height controller
Mist-maker	Fog production and controller
Exhaust fan	Air humidity controller
Arduino IDE 1.8.9, fritzing	Temperature and Humidity

Commented [u44]: Correct use of capital letters!

Commented [B645R44]: Corrected F to f and t to T

### Cultivation Process Procedure

Mushroom cultivation process procedure was carried out inside FRP House and utilized the organic components which are mixed and fermentation process for 4 days to be a compost, and then fill into bag log evenly in a plastic sacks assembled inside FRP House. The layers of compost were pasteurized inside FRP house with closed cover condition tightly and then fogging with hot air at temperature 60-65°C for 8 hours. The mushroom seeds were inside over the bag logs of compost and then to be incubated for 3 days at around 29-30°C of inside air temperature. The treatment during mushroom growth up to harvest periods comprised of the inside air temperature, humidity and soil water content.

### Extraction of the Active Compound Ergothioneine

The isolation of ergothioneine EGT compounds from the harvested fresh mushrooms was carried out by the extraction method refers to the method developed by Ito et al. (2011) and Nguyen et al. (2012) with some modifications. Pre-treatment (blanching and non-blanching), mushroom before drying methods by electric oven drying.

The experimental factors of extraction employed the temperature 40°C and 60°C respectively with the variation of the extraction solvent (water and ethanol 30% (v/v), 50% (v/v), 70% ethanol (v/v), and ethanol 100 % (v/v)). The extraction procedure utilized 10 grams of dry mushroom powder and 200 mL of solvent which has been heated in a shaking water bath according to variations in temperature. The solvent along with the solute was continuously agitated at 100 rpm for 1 hour, then cooled at room temperature for 2 hours. Then it was centrifuged at 600 rpm for 15 minutes at 25°C. The achieved of the process is supernatant which was transferred to a conical tube for further evaporation using a vacuum evaporator at a temperature of 40°C to evaporate the remaining solvent up to be a paste of EGT extract. Furthermore, the paste of EGT was dried by the freeze-drying method. The dried EGT sample was then weighed to measure as the extraction yield.

### EGT concentration analysis

Analysis of the concentration of EGT in the oyster mushroom extract used the HPLC method referring to the method used by Kalaras et al. (2017) with some modifications. The

mushroom powder (0.5 g) and 7 ml of ethanolic was put into a 15 ml centrifuge tube (consisting of 10 mM dithiothreitol, 100 M betaine, 100 M 2-mercapto-1-methyl imidazole) and 3 ml of distilled water was added and homogenized with a vortex for 10 seconds. A total of 2 mL of 1% SDS solution dissolved in ethanol was added and homogenized with a vortex for 10 seconds. Then the suspension was centrifuged for 20 minutes at 4000 rpm and 25°C. The supernatant formed was transferred to a 15 mL centrifugation tube. Then, 1 mL of the supernatant was put into a micro tube and allowed to stand for 24 hours. The solid formed from this process is then dissolved into 0.5 mL of aqua bides and homogenized using a vortex until it dissolves completely. Samples that have been stored in micro-tubes were centrifuged at 10,000 rpm for 1 minute. The supernatant formed was then filtered using a syringe filter (0.45 100 m) and put into a glass vial for HPLC analysis.

HPLC analysis was performed using column C18. The volume of the solution injected was 10 µL. The mobile phases used mobile phase A (3% acetonitrile, 0.1% TEA, 50 mM dibasic sodium phosphate dissolved in distilled water), mobile phase B (acetonitrile), and mobile phase C (water). The separation was performed on the elution gradient as follows: 0 minutes 15:85 (B:C), 0-5 minutes set at a slope of 5:15:85 (A:B:C), 5-6 minutes set at a slope of 10:90 (B:C), 6-8 minutes at 3:97 (B:C), and 8-15 at 3:97 (B:C). EGT was detected at a wavelength of 254 nm with a peak retention time of 5.7 min which was quantified using an external standard curve.

The antioxidant activity of EGT from edible mushroom was carried out by measuring the radical scavenging activity of DPPH referring to the method of Pahila et al. (2019). The analytical procedure comprised of 50 L of straw mushroom extract is added to 50 L of DPPH solution (100 M in 85% ethanol) and stirred using a vortex. After 15 minutes, the solution mixture was put into a 50 L Pyrex NMR capillary tube, then the DPPH radical spin resonance was measured with a spectrometer at a wavelength of 517. The spectrometer settings as microwave power, 1.2 mW; microwave frequency 9149.3 MHz; field magnet, 325.5 25 mT; and the sweep time, 30 seconds. Various concentrations of EGT were measured for resonance to construct a standard curve. The radical scavenging activity of DPPH was expressed as mmol equivalent of EGT per mL of sample.

## RESULTS AND DISCUSSION

### FRP House

The prototype of the FRP house is shown in Figure 3. Condition of the air temperature, air humidity and water content of the media inside the FRP house during mushroom cultivation are monitored automatically. The variation of air temperature around 29-39°C is relatively stable, while condition at day, night and rainy, resulted in high fluctuated of air humidity 40-98% with the water content of the media around 39-99%.

The devices inside the mushroom's FRP house consists of circuits, input blocks and output blocks which are joint by the Nodemcu microcomputer to control the air condition inside mushroom's FRP house. The input block is a soil moisture sensor and BME280 as a temperature, humidity and barometric detector. The sensor will generate an input value for the Nodemcu microcomputer, this value will be processed by Nodemcu which produces an output value to the connected devices. While the output block is a receiver a value generates by sensor through Nodemcu, such as a heater will operate if the temperature inside the mushroom's FRP house is low and the mist-maker will turn off if the humidity inside the mushroom's FRP house is sufficient. Nodemcu has a Wi-Fi module that is able to save the values and data in the database, this can make it easier to use a smartphone to access mushroom's FRP house condition

even the values or data remotely. The IoT control system is setup for operating the hot air exhaust with the mist sprayer process taking place in parallel if the air temperature at above 39°C with humidity below 60%. And when the opposite condition occurred (below 29°C), thus the water heater will actively operate spraying hot air vapor into the FRP House. This methods of IoT control mechanism will reduce the human intervention so that the growth process of mycelium and pinhead of fungal embryos can achieve optimally.

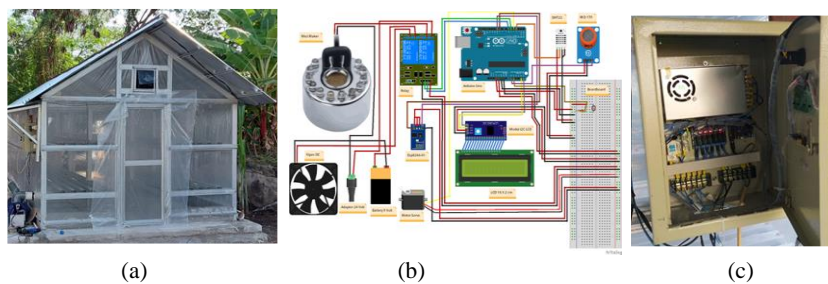

Figure 3. The prototype of the FRP house (a) with IoT circuit (b) and panel control box(c)

The generated measuring instrument and sensors performance corresponded the proposed elapsed time through the interface to display's monitor. In table 2 showed the comparison of sensor values with measuring instruments. Digital measuring instrument used to compare sensor values such as Hygrometer, lux meter and the average temperature difference of 0.7°C and humidity of 2.1%.

Table 2. Temperature and humidity sensor testing

Temperature			Humidity		
Sensor	Device	Diff	Sensor	Device	Diff
31.7	30.8	0.9	77	76	1
31.6	30.7	0.9	78.3	77	1.3
31.7	30.7	1	78.9	78	0.9
31.8	30.7	1.1	78.3	78	0.3
31.8	30.7	1.1	79.1	79	0.1
31.8	31.3	0.5	80.2	79	1.2
32.2	31.1	1.1	83.4	82	1.4
32.2	31.2	1	82	82	0
32.1	31.5	0.6	81.3	81	0.3
32.1	31.1	1	81.2	81	0.2

Table 3 is a comparison graph of sensor values with measuring instruments. Digital measuring tools used to compare sensor values such as mini-Hygrometer, lux meter and carbon detector. The test was carried out by taking samples 30 times by getting an average temperature difference of 0.91°C, humidity 0.89%. Furthermore, the light sensor gets an average difference

Commented [u46]: Describe each image

Commented [B647R46]: corrected

Commented [i-448]: Corrected 0C to °C

Commented [u49]: Recheck!

of 19.76% and gas content of 10.13 ppm. The second test evaluates the performance of the tool and obtains an accuracy rate of success of 93.3%.

Table 3. Light sensor and CO<sub>2</sub> content

light			Gas Content		
Sensor	Device	Diff	Sensor	Device	Diff
192	175	17	21	10	11
187	144	43	33	12	21
182	152	30	16	9	7
103	100	3	24	16	8
170	145	25	22	20	2
-	-	-	-	-	-
-	-	-	-	-	-
144	124	20	18	7	11
169	123	46	10	3	7
118	115	3	15	8	7
124	121	3	24	16	8
128	122	6	30	20	10

#### Effect of FRP House to Mushroom quality

Air conditions and lighting inside mushroom's FRP house day and night during the mushroom growth (Figure 4) contribute for the effect to the quality of harvested fresh mushroom. The results of quality analysis indicated that the range of phenotype length of 2.5-10 cm, diameter of 3-10 cm and weight 10-120 gram (Figure 5), in general the mushrooms growth from organic media are longer and heavier than non-organic growth media with more uniform dimensions except for the diameter of phenotype.



Commented [u50]: In English! complete the unit!

Figure 4. Fluctuation of air temperature, RH, and moisture content inside FRP House



Figure 5. Dimension of harvested oyster mushroom

The hardness test per fruit and the moisture content of the mushrooms were carried out by comparing the mushrooms ~~on organic media and non organic media on the FRP house with the housing~~ at the farm level as shown in Table 4, indicating that the mushrooms in the ~~model~~ FRP house were harder and less water content than that ones at the farmer mushroom's housing at the farm level.

Commented [u51]: Make some effective sentences!

Commented [B652R51]: The hardness test per fruit and the moisture content of the mushrooms were carried out by comparing the mushrooms ~~on organic media and non organic media on the FRP house with the housing~~ at the farm level as shown in Table 4, indicating that the mushrooms in the ~~model~~ FRP house were harder and less water content than that ones at the farmer mushroom's housing at the farm level.

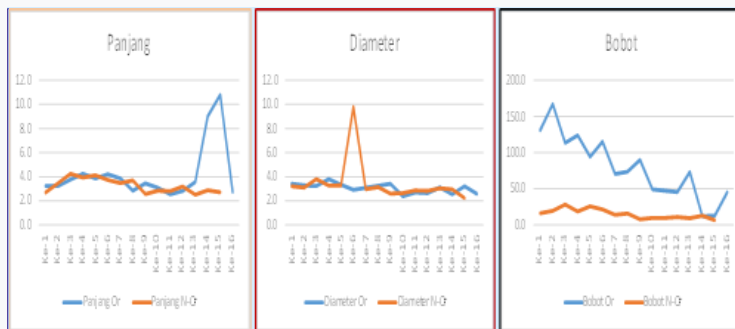

Figure 6 Dimension of fresh harvested mushroom

Commented [u53]: In English! And clarify the image resolution!

Commented [B654R53]: Figure 6 is deleted and Table 4 is represented

Table 4. Characteristics of straw mushroom

No	Parameter	average
1.	texture	865,0±100,0
2	Dimension	
	- Length (mm)	41,5±6,0
	- Width (mm)	60,0±4,0
	- Height (mm)	29,5±9,0



### Micro Laboratory Analysis

The results of micro-laboratory analysis (Table 5) showed that the fresh harvested mushroom are negative from total fungus and salmonella

Commented [u55]: Recheck!

Commented [B656R55]: Number of Table is corrected from Table 6 to Table 5

Tabel 5. Analysis result of total fungus and salmonella

Code	Phase of fungus	Total fungus (cfu/g)	Salmonella (negative/25g)
A	Non organic mushroom, Bloom	2.9x10 <sup>5</sup>	negative
B	Non organic mushroom, fresh	1.0x10 <sup>5</sup>	negative
C	Organic mushroom, bloom	3.5x10 <sup>4</sup>	negative
D	Organic mushroom, fresh	6.5x10 <sup>4</sup>	negative
E	non organic mushroom, bloom	1.7x10 <sup>6</sup>	negative
F	non organic, mushroom, fresh	5.4x10 <sup>4</sup>	negative

### Extraction of the Active Compound Ergothioneine

The results of the analysis on functional compounds of EGT in oyster mushrooms using the HPLC method, a graphic recording of the results of HPLC analysis of dried mushrooms with standard ethanol solvent. The average recording results from the EGT chromatography results were 0.674 mg/g as shown in Table 6

Table 6. Results of chromatogram graphic data processing from mushroom extract

Code	Area	Intercept	Slope	V (ml)	fp	B.s (g)	C (ppm)	C (%)	mg/g DW
Organic, et 70%	2,005	0,1501	0,0643	20	250	0,2006	719032,64	71,90	0,799
	2,0309	0,1501	0,0643	20	250	0,2006	729072,50	72,91	0,810
Non organic, et 70%	2,2289	0,1501	0,0643	20	250	0,2688	601370,99	60,14	0,668
	2,2626	0,1501	0,0643	20	250	0,2688	611119,98	61,11	0,679
Ethanol 96%	2,2255	0,1501	0,0643	20	250	0,2034	793432,33	79,34	0,882
	2,0676	0,1501	0,0643	20	250	0,2034	733066,64	73,31	0,815
Powder, organic	1,3702	0,1501	0,0643	20	250	0,2022	469216,53	46,92	0,521
	1,3862	0,1501	0,0643	20	250	0,2022	475369,69	47,54	0,528
Powder, anorganic	1,3431	0,1501	0,0643	20	250	0,2009	461763,43	46,18	0,513
	1,2709	0,1501	0,0643	20	250	0,2009	433817,65	43,38	0,482

The extraction process breaks down the bonds among the molecules of the material so that EGT and phenol compounds are produced with varying concentrations depending on the type of solvent used (Table 7). The results of the standard solution analysis showed that the

EGT compound had a retention time of  $3.33 \pm 0.06$  minutes, while the mushroom sample showed a retention time of 3.28 to 3.30 minutes.

Table 7. Recapitulation of EGT characterization data from edible mushrooms

Solvent	Concentration EGT (mg/g DW)	Total Phenol (mg/g DW)
Ethanol 96%	$0,805 \pm 0.01$	$0,015 \pm 0.00$
Ethanol 70%	$0,848 \pm 0.05$	$0,025 \pm 0.00$

The extraction process using 70% ethanol produced higher concentrations of EGT and phenol than the extraction process using 96% ethanol. This shows that 70% of ethanol solvent is more effective used to bind EGT and phenol compounds in oyster mushrooms than that in pure solvents. This result is in line with the previous study conducted by Nguyen et al. (2012). The process of extracting the *Flammulina velutipes* mushroom using 70% ethanol was able to produce EGT and phenol compounds with higher concentrations than that the extraction using 50% and 100% of ethanol, with values of  $2.05 \pm 0.18$  mg/g and  $3.65 \pm 0,08$  DW, consecutively.

The extraction process that has been carried out can break down the bonds between the molecules of the material so that EGT and phenol compounds are produced with varying concentrations depending on the type of solvent used (Table 8). The results of the standard solution analysis showed that the EGT compound had a retention time of  $3.33 \pm 0.06$  minutes, while the straw mushroom sample showed a retention time of 3.28 to 3.30 minutes.

Table 8. Methods and varying concentrations type of solvent for EGT

Species of mushroom	Methods	Concentration Ergothioneine (mg/g BK)
<i>Flammulina velutipes</i> Ref.: Nguyen et al. (2012)	Water	$1.50 \pm 0.21$
	Ethanol 70%	$2.05 \pm 0.18$
	Methanol 70%	$1.86 \pm 0.04$
	Acetone 70%	$1.92 \pm 0.07$
<i>Pleurotus eryngii</i>	Hot water	0.86
<i>Pleurotus citrinopileatus</i>	Ref.: Yen et al. (2018)	3.73
<b>Oyster Mushroom</b>	<b>Ethanol 70%</b>	<b><math>0.67 \pm 0.01</math></b>

The extraction process for active compounds (Table 9), such as EGT and phenol, is influenced by several factors, such as solvent polarity and process conditions. A mixture of solutions has the ability to bind the active compound better than the pure solvent. This is due to the mixing of nonpolar solvents with water which can increase the polarity index of the solvent so that the extraction efficiency increases.

Commented [u57]: Correct capitalization!

Commented [B658R57]: Water is corrected

In addition, the increase in extraction temperature was positively correlated to the increase in antioxidant activity and polyphenols (flavonoids and total phenol), while the increase in extraction time was not positively correlated to the increase in antioxidant activity and polyphenols. In addition, the presence of agitation during the extraction process also contributes to increasing the extraction yield. This happens because the agitation process can increase the rate of diffusion and minimize the barriers to mass transfer from the solid surface into the solution (Muhamad et al., 2014).

Table 9. ~~the~~ Results of chromatograph analysis of mushroom samples

Code	Area	V (ml)	fp	B.s (g)	C (ppm)	C (%)
Organic	2,005	20	250	0,20	719032,6	71,90
Non organic	2,2289	20	250	0,27	601371,0	60,14
Ethanol 96%	2,2255	20	250	0,20	793432,3	79,34
Powder (organic)	1,3702	20	250	0,20	469216,5	46,92
Powder (unorganic)	1,3431	20	250	0,20	461763,4	46,18

Commented [u59]: Recheck!

Commented [B660R59]: The is deleted and result changed into Results

Table 10 showed that the role in synthesizing EGT is the methyltransferase enzyme which is encoded by the EGT gene and specifically remodels histidine into EGT compounds (Stampfli et al., 2020). The results of another study stated that the biosynthesis of EGT is a complex synthesis process involving various types of amino acids and carbon sources. However, in principle there are three types of amino acids that play an important role in EGT biosynthesis, namely methionine, histidine, and cysteine. Histidine acts as a starting material that plays a role in the whole series of EGT biosynthesis. Cysteine serves to provide a source of sulfur atoms, while methionine which contains the protein S-adenosyl-l-methionine (SAM) acts as a precursor in reactions involving methyl groups. In supporting its growth, cells can use dextrose, fructose, glycerol, maltose, and sucrose as carbon sources. A suitable carbon source for EGT biosynthesis is glycerol because it is able to maintain cells in a longer stationary growth phase. In the glycolysis cycle, glycerol is broken down into glycerol-3 phosphate by the enzyme glycerol kinase. Furthermore, glycerol-3 phosphate is broken down by the enzyme glyceraldehyde-3 phosphate dehydrogenase to glyceron-P which is then overhauled by triosephosphate isomerase to glyceraldehyde 3 phosphate (GAP). GAP acts as a precursor in the glycolysis process to produce pyruvic acid which will also be a substrate in the Krebs cycle. Consumption of large amounts of pyruvic acid can stimulate enzymatic reactions of amino acids to produce EGT (Yu et al., 2020).

Table 10. Concentration of ergothioneine in different species of mushroom.

Mushroom Species	Ergothioneine Content*	Mushroom Species	Ergothioneine Content*
<i>Fomitopsis pinicola</i>	0.07 ± 0.01	<i>Polyozellus multiplex</i>	0.51 ± 0.01

Mushroom Species	Ergothioneine Content*	Mushroom Species	Ergothioneine Content*
<i>Ganoderma applanatum</i>	0.06 ± 0.02	<i>Ramaria botrytis</i>	0.29 ± 0.03
<i>G. lucidum</i>	0.08 ± 0.02	<i>S. granulata</i>	0.09 ± 0.03
<i>G. neo-japonicum</i>	0.07 ± 0.00	<i>Lampteromyces japonicus</i>	0.43 ± 0.16

\*mg/g dw; Mean ± SD.

Sources: Modified from Lee et al., 2009, Ito et al., 2011.

## CONCLUSION

The research results showed that the cultivation of oyster mushroom in an FRP house with ceramic floors and plastic walls and an IoT management. The temperature of the air inside was between 29 and 35 degrees Celsius, and the relative humidity was between 60% and 90%. The weight of fresh oyster mushroom was 865 mg. The average length, width, and height of the fresh mushroom were 41.5 mm, 60.0 mm, and 29.5 mm, respectively. The microbiological test confirmed that there was no salmonella infection in the collected mushrooms. The stage of mushrooms have less total fungus than the bloom-stage mushrooms. The extraction standard method employs an EGT content of 0.674 mg/g as determined by chromatography data analysis. The oyster mushrooms can be consumed as a healthy meal, and the study of EGT showed also very prospective as one of immunotherapeutic food.

## REFERENCES

- Adiandri, R.S., Hidayah, N., dan Nugraha, S. 2018. Identification of amino acid, fatty acid, mineral content and respiration rate of straw mushroom in different stage of maturity. Proceeding the international seminar on tropical horticulture, 239-248
- Borodina, I., Kenny, L.C., McCarthy, C.M., Paramasivan, K., Pretorius, E., Roberts, T.J., van der Hoek, S.A, dan Kell, D.B. 2020. The biology of ergothioneine, an antioxidant nutraceutical. Nutrition Research Review, 33, 190-217
- Cheah, I.K., dan Halliwell, B. 2020. Could ergothioneine aid in the treatment of coronavirus patients? Antioxidants, 9, 595
- Dhalsamant, K., Dash, S.K., Bal, L.M., dan Panda, M.K. 2015. Effect of perforation mediated MAP on shelf life of mushroom (*Volvarella volvacea*). Scientia Horticulturae, 189, 41-50
- Halliwell, B., Cheah, I.K., dan Tang, R.M.Y. 2018. Ergothioneine – a diet-derived antioxidant with therapeutic potential. FEBS Letters, 592, 3357-3366
- Ito, T., Kato, M., Tsuchida, H., Harada, E., Niwa, T., dan Osawa, T. 2011. Ergothioneine as an anti-oxidative/anti-inflammatory component in several edible mushrooms. Food Sci. Technol. Res., 17(2), 103-110
- Jamjumroon, S., Wongs-Aree, C., McGlasson, W.B., dan Sriloang, V. 2012. Extending the shelf-life of straw mushroom with high carbon dioxide treatment. Journal of Food Agriculture and Environment, 10(1):78-84

Commented [u61]: Note the writing of the Latin name

Commented [B662R61]: Change into italic style

Commented [u63]: Fix reference writing!

Commented [B664R63]: "Modified from" deleted

Commented [u65]: Recheck!

Commented [B666R65]: in an FRP house with ceramic

Commented [u67]: Average may be?

Commented [B668R67]: Checked with the words "The average" and "the measured tobe" is deleted

- Kalaras, M.D., Richi, J.P., Calcagnotto, A., dan Beelman, R.B. 2017. Mushrooms: a rich source of the antioxidants ergothioneine and glutathione. *Food Chemistry*, 233, 429-433
- Kopinski, L., dan Kwiatkowska-Marks, S. 2012. Utilization of waste newspaper using oyster mushroom mycelium. *Industrial & Engineering Chemistry Research*, 51, 4440-4444
- Nguyen, T.H., Nagasaka, R., dan Ohshima, T. 2012. Effects of extraction solvents, cooking procedures and storage conditions on the contents of ergothioneine and phenolic compounds and antioxidative capacity of cultivated mushrooms *Flammulina velutipes*. *International Journal of Food Science & Technology*, doi: 10.1111/j.1365-2621.2012.02959.x
- Nur Sakinah, M.J., Misran, A., Mahmud, T.M.M., Abdullah, S., dan Azhar, M. 2020. Evaluation of storage temperature, packing system and storage duration on postharvest quality of straw mushroom (*Volvarella volvacea*). *Food Research*, 4(3), 679-689
- Pahila, J., Ishikawa, Y., dan Ohshima, T. 2019. Effects of ergothioneine-rich mushroom extract on the oxidative stability of astaxanthin in liposomes. *Journal of Agricultural and Food Chemistry*, 67, 3491-3501
- Repine, J.E., dan Elkins, N.D. 2012. Effect of ergothioneine on acute lung injury and inflammation in cytokine insufflated rats. *Preventive Medicine*, 54, S79-S82
- Shinozaki, Y., Furuichi, K., Toyama, T., Kitajima, S., Hara, A., Iwata, Y., Sakai, N., Shimizu, M., Kaneko, S., Isozumi, N., Nagamori, S., Kanai, Y., Sugiura, T., Kato, Y., dan Wada, T. 2017. Impairment of the carnitine/organic cation transporter 1-ergothioneine axis is mediated by intestinal transporter dysfunction in chronic kidney disease. *Kidney Int.*, 92(6), 1356-1369
- Song, T.Y., Lin, H.C., Chen, C.L., Wu, J.H., Liao, J.W., dan Hu, M.L. 2014. Ergothioneine and melatonin attenuate oxidative stress and protect against learning and memory deficits in C57BL/6J mice treated with D-galactose. *Free Radic Res.*, 48(9), 1049-60
- Yoshida, S., Shime, H., Matsumoto, M., Kasahara, M., dan Seya, T. 2019. Anti-oxidative amino acid L-ergothioneine modulates the tumor microenvironment to facilitate adjuvant vaccine immunotherapy. *Front Immunol.*, 10, 671

## 1b.6.bHasil review dari Reviewer C 18-07-2023

### HASIL REVIEW DARI REVIEWER 2:

#### Exploration of Oyster Mushrooms for Functional Fresh Food

**Abstract.** This article presents studies on the physicochemical quality of oyster mushrooms grown within a housing and controlled by the Internet of Things (IoT). The goals of this study were to assess (1) the impact of indoor air quality on the growth and quality of mushrooms and (2) the antioxidant content of oyster mushrooms. In this study, the air temperature and humidity per unit mass of oyster mushroom per unit time will be recorded and automatically controlled by an IoT system. Additionally, their physicochemical and microbiological quality were evaluated using physico-analytical instruments, and the potency of their ergothioneine (EGT) content was investigated using the HPLC method. The results showed that temperature of the air inside was between 29 and 35 degrees Celsius, and the relative humidity was between 60% and 90%. The weight of fresh oyster mushroom was 865 mg. The length, width, and height of the fresh mushroom were measured to be 41.5 mm, 60.0 mm, and 29.5 mm, respectively. The microbiological test confirmed that there was no salmonella infection in the collected mushrooms. The button-stage mushrooms have less total fungus than the bloom-stage mushrooms. The extraction standard method employs an EGT content of 0.674 mg/g as determined by chromatography data analysis. The oyster mushrooms can be consumed as a healthy meal, and the study of EGT showed also very prospective as one of immunotherapeutic food.

Keywords: ergothioneine, Fibre-reinforced plastic house, Internet of think, oyster mushrooms

#### INTRODUCTION

The oyster mushroom is a type of mushroom that specifically grows in tropical countries such as Indonesia. oyster mushrooms are grown on aggregate media one of them is the paddy waste from the paddy cultivation. Therefore, generally at the rice production centre area mostly becoming the centre for mushrooms production. This can be correlated with the availability of biomass as the main growing media for mushroom.

Cultivating high quality of the mushrooms required high-quality seeds, the high-quality media resources as well as the optimal environment due to the mushrooms are sensitive to climate change. To fulfil the optimum condition for mushrooms cultivation, an adequate production house is required to be implemented by environment controller and high-quality safety materials for growing media and to avoid using industrial in order to produce free contaminant (Kopinski, and Kwiatkowska-Marks, 2012).

A prototype of Fiber Reinforced Plastic (FRP) house (Ridwan Rachmat and Horibe, 1999) is a proper construction for mushroom production housing, and it is implemented with an Internet of things (IoT) based connected to various devices microcontroller. The mushroom production house used IoT control system is to make it easier to monitor the air condition inside the house online by mean of displaying the value generated from the installed sensors inside the house. According to Shasha Asyarita & Ani Lestari [7], temperature and humidity in production house of mushrooms greatly affect the growth process of mushrooms. So that the mushrooms do not rot, brown and wilt, the humidity in the mushroom production house should not be too high or low, ranging from 75%-90% at the humidity level of the mushroom production house.

**Commented [NN1]:** Secara konten naskah OK. Secara umum naskah POOR.

- Judul kurang mewakili isi
- Tidak Fokus
- Metode: poor
- Pembahasan: kurang dalam
- Bhs Inggris: Poor
- (Jika anda tidak yakin dg bhs Inggris, sebaiknya submit naskah bhs Indonesia saja. Reviewnya nggak ribet).

**Commented [NN2]:** Apa maksudnya? Adakah Suhu dan Kelembaban per unit massa? Perbaiki dan perjelas

**Commented [NN3]:** °C

**Commented [NN4]:** Pada umur panen berapa haris?

**Commented [NN5]:** Paragraf meloncat-loncat. Perlu ditata ulang:  
Paragraf 1 OK.  
Keunggulan (karakteristik) mushroom  
Data (statistic) produksi/konsumsi mushroom  
Syarat tumbuh dan budidaya mushroom yang baik.  
Peranan IOT dalam budidaya mushroom yang baik.  
Tujuan penelitian.

**Commented [NN6]:** Apa maksudnya?

Research by Dhiya et al [5] who conducted an analysis of the efficiency of the edible mushroom stated that the growth of high consumption of mushrooms was due to the high protein content of edible mushrooms. The mushroom has good properties for the nutritional needs of the human body such as being rich in protein, vitamin C and various water-soluble vitamins (riboflavin, biotin and thiamine), fat (5.7%), carbohydrates (56,8%), amino acids, unsaturated fats, essential minerals (sodium, potassium and phosphorus) and has a low calorific value [6].

Mushrooms contain various types of nutrients those are beneficial to the health of the human body, such as carbohydrates, proteins, and fats. Several types of essential nutrients found in edible mushrooms include amino acids (glutamic acid, proline, phenylalanine, lysine, histidine, etc.), fatty acids (lauric, palmitic, oleic, lenoleic, etc.), potassium, calcium, and phosphorus (Adiandri et al., 2018). One type of essential amino acid found in mushrooms is ergothioneine (EGT). EGT is a derivative of histidine which contains functional groups of sulfur atoms and hydrogen atoms (-SH) and it can only be synthesized by fungi and actinobacteria (Borodina et al., 2020; Halliwell et al., 2018).

Mushrooms as a food source have been reported to have the highest level of ergothioneine compared to any other food source (Dubost et al., 2006, Dubost et al., 2007). In an early report, it has been shown that if we consume mushrooms as our regular food, the bioavailability of ergothioneine remains in our body (Weigand-Heller et al., 2012). The ergothioneine chemical compound is accumulated in the fruiting bodies as well as in the mycelia of the mushroom (Borodina et al., 2019, Kalaras et al., 2020). Several studies have been conducted with samples of mushrooms to describe improved ergothioneine production by the addition of several additives, such as aspartic acid, lysine, and methionine, which demonstrate increased ergothioneine biosynthesis (Lee et al., 2009). In addition, it has also been described that the production of ergothioneine increases with increased pH and is higher under alkaline conditions (Huang et al., 2015).

Research on the identification and isolation of EGT from several fungal varieties has been carried out. The content of EGT in mushrooms is quite high and has good antioxidant activity. In addition, differences in genus and species of fungi have different chemical compositions contained in them so that it affects the proportion of EGT in mushrooms (Kalaras et al., 2017). The results of the literature study indicate that the identification and isolation of EGT from edible mushroom has never been done. Therefore, research to explore the opportunity to use edible mushroom as a source of EGT needs to be done.

The provision of production house that meets food safety requirements is absolutely necessary to produce safe oyster mushrooms for consumption. Meanwhile the technology development of this mushroom production that meets food safety standards for the isolation of ergothioneine as an antioxidant is a potential matter in exploration of mushroom is still limited. This paper describes the research results of the prototype of FRP house with the air condition variation inside the house and the effect of air condition against mushroom quality. The effect of the IoT implementation in controlling the air condition system as well as minimizing the human contact during oyster mushroom growing during cultivation periods, and to explore the value added of mushroom through the ergothioneine (EGT) analysis as the of antioxidant content in mushroom.

## MATERIAL AND METHODS

The scope of research includes (1) constructing a prototype of FRP house with IoT control system for oyster mushroom cultivation; (2) to evaluate the air condition variation inside

**Commented [NN7]:** Mohon disusun:  
Kapan dan dimana penelitian dilakukan (jika perlu berikan koordinat geografisnya).  
Deskripsi rumah jamur

the house and the effect of air condition against mushroom growth and quality; (3) Analysis of antioxidant content in mushroom. The materials and chemicals used in this research are analytical grade chemicals. The effectiveness of antioxidant properties on isolated EGT was measured by in vitro method.

**FRP House**

The FRP house built in a prototype scale (Figure 1) at an area of 650 cm x 350 cm with a light steel alloy as the frames and the roof is covered by a thin metal sheet and all the wall blanketed by fibre reinforced plastic (FRP), and white tile's floor, there are two shelves at inside the FRP house with two racks of 400 cm length and 100 cm width respectively.

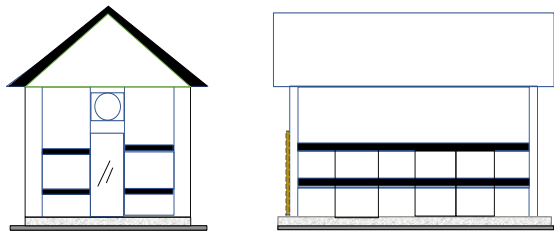

Figure 1. Prototype of FRP house model of straw mushroom

**Commented [NN8]:** Menjadi tidak fokus, kearah mana makalah ini: perancangan rumah jamur, kinerja rumah jamur, karakteristik jamur. Nomor (1) dan (2) jadikan 1 dengan focus pada kinerja system control rumah jamur.

The FRP House implemented with an Internet of Think (IoT) system (Figure 2) to actuate a set of devices to measure the parameters of air temperature, air humidity, moisture content of the media. The control devices are 30 nozzles of mist sprayer setup along the rack of shelves above the media which are connected with a special hose. Hot air temperatures above 35°C, caused the exhaust fan is on, whenever a drastic drop of air temperature inside the FRP house below 29°C, thus the heater mixer will operate automatically to increase the room temperature. The controller specification showed in Table 1 are set at day and night time with the elapsed time of intervals are enable to monitor the parameters conditions to avoid disturbance during mushrooms growth.

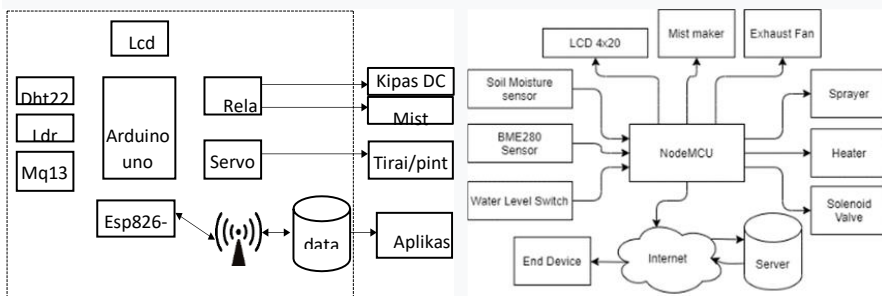

Figure 2. Architecture of IoT of production house in oyster mushroom

**Commented [NN9]:** Berikan dimensi utama

**Commented [NN10]:** Semua komponen gambar diinggriskan Beberapa nama komponen terpotong.



The Arduino Node MCU is an open-source platform based on IoT, which is able to implement various commands with programming languages. The application of the C programming language uses a sketch on the Arduino IDE (Integrated Development Environment), which is capable of programming various kinds of microcontrollers including Node MCU. The Node MCU has a small size compared to Arduino UNO, by using the ESP8266 module, there are GPIO (General-purpose input/output), PWM (Pulse Width Modulation), I2C, UART (Universal Asynchronous Receiver Transmitter), 1-Wire and ADC (Analog). to Digital Converter).

**Tabel 1.** Component and specification of control system.

Component	Specifications
Sensor BME280	Air temperature and Humidity sensor
Soil Moisture sensor	Soil moisture content controller
Water Level sensor	Water height controller
Mist-maker	Fog production and controller
Exhaust fan	Air humidity controller
Arduino IDE 1.8.9, Fritzing	temperature and Humidity

**Commented [NN11]:** Tambahkan 1 kolom untuk frekwensi sensor itu melakukan pengambilan data (tiap berapa menit/jam/hari)

### Cultivation Process Procedure

Mushroom cultivation process procedure was carried out inside FRP House and utilized the organic components which are mixed and fermentation process for 4 days to be a compost, and then fill into bag log evenly in a plastic sacks assembled inside FRP House. The layers of compost were pasteurized inside FRP house with closed cover condition tightly and then fogging with hot air at temperature 60-65°C for 8 hours. The mushroom seeds were inside over the bag logs of compost and then to be incubated for 3 days at around 29-30°C of inside air temperature. The treatment during mushroom growth up to harvest periods comprised of the inside air temperature, humidity and soil water content.

**Commented [NN12]:** Pengukuran suhu dan RH menggunakan alat dilakukan tiap berapa jam/hari? Jelaskan kapan panen dilakukan? (umur, atau ukuran)

### Extraction of the Active Compound Ergothioneine

The isolation of ergothioneine EGT compounds from the harvested fresh mushrooms was carried out by the extraction method refers to the method developed by Ito et al. (2011) and Nguyen et al. (2012) with some modifications. Pre-treatment (blanching and non-blanching), mushroom before drying methods by electric oven drying.

**Commented [NN13]:** Apakah ini satu parameter ini memadai untuk menilai Fungsional Food? Jika ya, berikan penekanan.

The experimental factors of extraction employed the temperature 40°C and 60°C respectively with the variation of the extraction solvent (water and ethanol 30% (v/v), 50% (v/v), 70% ethanol (v/v), and ethanol 100 % (v/v)). The extraction procedure utilized 10 grams of dry mushroom powder and 200 mL of solvent which has been heated in a shaking water bath according to variations in temperature. The solvent along with the solute was continuously agitated at 100 rpm for 1 hour, then cooled at room temperature for 2 hours. Then it was centrifuged at 600 rpm for 15 minutes at 25°C. The achieved of the process is supernatant which was transferred to a conical tube for further evaporation using a vacuum evaporator at a temperature of 40°C to evaporate the remaining solvent up to be a paste of EGT extract. Furthermore, the paste of EGT was dried by the freeze-drying method. The dried EGT sample was then weighed to measure as the extraction yield.

### EGT concentration analysis

Analysis of the concentration of EGT in the oyster mushroom extract used the HPLC method referring to the method used by Kalaras et al. (2017) with some modifications. The

mushroom powder (0.5 g) and 7 ml of ethanolic was put into a 15 ml centrifuge tube (consisting of 10 mM dithiothreitol, 100 M betaine, 100 M 2-mercapto-1-methyl imidazole) and 3 ml of distilled water was added and homogenized with a vortex for 10 seconds. A total of 2 mL of 1% SDS solution dissolved in ethanol was added and homogenized with a vortex for 10 seconds. Then the suspension was centrifuged for 20 minutes at 4000 rpm and 25°C. The supernatant formed was transferred to a 15 mL centrifugation tube. Then, 1 mL of the supernatant was put into a micro tube and allowed to stand for 24 hours. The solid formed from this process is then dissolved into 0.5 mL of aqua bides and homogenized using a vortex until it dissolves completely. Samples that have been stored in micro-tubes were centrifuged at 10,000 rpm for 1 minute. The supernatant formed was then filtered using a syringe filter (0.45 100 m) and put into a glass vial for HPLC analysis.

HPLC analysis was performed using column C18. The volume of the solution injected was 10 µL. The mobile phases used mobile phase A (3% acetonitrile, 0.1% TEA, 50 mM dibasic sodium phosphate dissolved in distilled water), mobile phase B (acetonitrile), and mobile phase C (water). The separation was performed on the elution gradient as follows: 0 minutes 15:85 (B:C), 0-5 minutes set at a slope of 5:15:85 (A:B:C), 5-6 minutes set at a slope of 10:90 (B:C), 6-8 minutes at 3:97 (B:C), and 8-15 at 3:97 (B:C). EGT was detected at a wavelength of 254 nm with a peak retention time of 5.7 min which was quantified using an external standard curve.

The antioxidant activity of EGT from edible mushroom was carried out by measuring the radical scavenging activity of DPPH referring to the method of Pahila et al. (2019). The analytical procedure comprised of 50 L of straw mushroom extract is added to 50 L of DPPH solution (100 M in 85% ethanol) and stirred using a vortex. After 15 minutes, the solution mixture was put into a 50 L Pyrex NMR capillary tube, then the DPPH radical spin resonance was measured with a spectrometer at a wavelength of 517. The spectrometer settings as microwave power, 1.2 mW; microwave frequency 9149.3 MHz; field magnet, 325.5 25 mT; and the sweep time, 30 seconds. Various concentrations of EGT were measured for resonance to construct a standard curve. The radical scavenging activity of DPPH was expressed as mmol equivalent of EGT per mL of sample.

## RESULTS AND DISCUSSION

### FRP House

The prototype of the FRP house is shown in Figure 3. Condition of the air temperature, air humidity and water content of the media inside the FRP house during mushroom cultivation are monitored automatically. The variation of air temperature around 29-39°C is relatively stable, while condition at day, night and rainy, resulted in high fluctuated of air humidity 40-98% with the water content of the media around 39-99%.

The devices inside the mushroom's FRP house consists of circuits, input blocks and output blocks which are joint by the Nodemcu microcomputer to control the air condition inside mushroom's FRP house. The input block is a soil moisture sensor and BME280 as a temperature, humidity and barometric detector. The sensor will generate an input value for the Nodemcu microcomputer, this value will be processed by Nodemcu which produces an output value to the connected devices. While the output block is a receiver a value generates by sensor through Nodemcu, such as a heater will operate if the temperature inside the mushroom's FRP house is low and the mist-maker will turn off if the humidity inside the mushroom's FRP house is sufficient. Nodemcu has a Wi-Fi module that is able to save the values and data in the database, this can make it easier to use a smartphone to access mushroom's FRP house condition

**Commented [NN14]:** Apa ini = ethanol? Atau sesuatu yang bersifat ethanol?

**Commented [NN15]:** Sebaiknya pembahasan dipilah jadi 3 sub: Kinerja rumah jamur dan system kontrolnya, Karakteristik jamur (dimensi), Karakteristik Jamur yang berkaitan dg Fungsional food.

**Commented [NN16]:** Bagian ini mestinya membahas bagaimana kinerja rumah jamur terutama mengenai sensor dan system kontrolnya. Apakah berfungsi dengan baik?

even the values or data remotely. The IoT control system is setup for operating the hot air exhaust with the mist sprayer process taking place in parallel if the air temperature at above 39°C with humidity below 60%. And when the opposite condition occurred (below 29°C), thus the water heater will actively operate spraying hot air vapor into the FRP House. This methods of IoT control mechanism will reduce the human intervention so that the growth process of mycelium and pinhead of fungal embryos can achieve optimally.

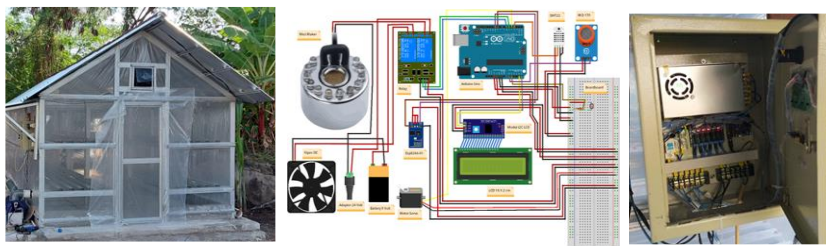

Figure 3. The prototype of the FRP house with IoT circuit

The generated measuring instrument and sensors performance corresponded the proposed elapsed time through the interface to display's monitor. In table 2 showed the comparison of sensor values with measuring instruments. Digital measuring instrument used to compare sensor values such as Hygrometer, lux meter and the average temperature difference of 0.7°C and humidity of 2.1%.

Table 2. Temperature and humidity sensor testing

Temperature			Humidity		
Sensor	Device	Diff	Sensor	Device	Diff
31.7	30.8	0.9	77	76	1
31.6	30.7	0.9	78.3	77	1.3
31.7	30.7	1	78.9	78	0.9
31.8	30.7	1.1	78.3	78	0.3
31.8	30.7	1.1	79.1	79	0.1
31.8	31.3	0.5	80.2	79	1.2
32.2	31.1	1.1	83.4	82	1.4
32.2	31.2	1	82	82	0
32.1	31.5	0.6	81.3	81	0.3
32.1	31.1	1	81.2	81	0.2

Table 3 is a comparison graph of sensor values with measuring instruments. Digital measuring tools used to compare sensor values such as mini-Hygrometer, lux meter and carbon detector. The test was carried out by taking samples 30 times by getting an average temperature difference of 0.91 0C, humidity 0.89%. Furthermore, the light sensor gets an average difference of 19.76% and gas content of 10.13 ppm. The second test evaluates the performance of the tool and obtains an accuracy rate of success of 93.3%.

**Commented [NN17]:** Dari mana? Tabel 2 tital diff 9.2 dari 10 data (rata-rata 0.92) Sedangkan Diff RH lebih kecil lagi ???  
Berapa kali pengambilan data (30?)  
Mengapa yang ditampilkan Cuma 10?

**Commented [NN18]:** Mengapa data yang disajikan Cuma 10?

Table 3. Light sensor and CO<sub>2</sub> content

light			Gas Content		
Sensor	Device	Diff	Sensor	Device	Diff
192	175	17	21	10	11
187	144	43	33	12	21
182	152	30	16	9	7
103	100	3	24	16	8
170	145	25	22	20	2
-	-	-	-	-	-
-	-	-	-	-	-
144	124	20	18	7	11
169	123	46	10	3	7
118	115	3	15	8	7
124	121	3	24	16	8
128	122	6	30	20	10

#### Effect of FRP House to Mushroom quality

Air conditions and lighting inside mushroom's FRP house day and night during the mushroom growth (Figure 4) contribute for the effect to the quality of harvested fresh mushroom. The results of quality analysis indicated that the range of phenotype length of 2.5-10 cm, diameter of 3-10 cm and weight 10-120 gram (Figure 5), in general the mushrooms growth from organic media are longer and heavier than non-organic growth media with more uniform dimensions except for the diameter of phenotype.

**Commented [NN19]:** Jelaskan umur panen berapa hari? Bahaslah apakah ukuran ini normal, super, atau kecil?

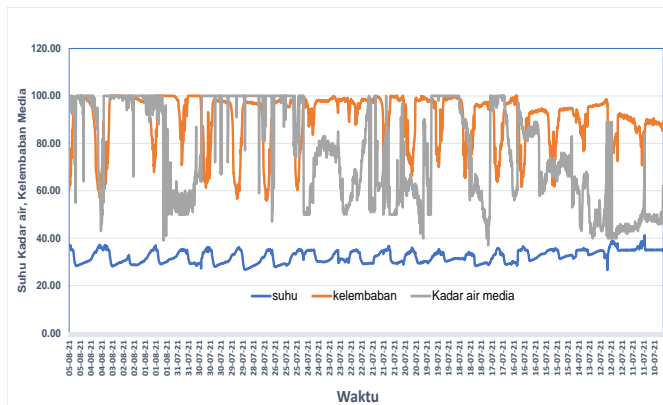

Figure 4. Condition of air temperature, RH, and moisture content inside FRP House

**Commented [NN20]:** Gambar ini mestinya digunakan untuk membahas kinerja rumah jamur dan fungsi sensor dan kontrolnya. Apakah rumah jamur berfungsi dengan baik, yaitu memberikan lingkungan yang sesuai dengan kebutuhan untuk pertumbuhan jamur. Apakah system control bekerja dengan baik, yaitu menciptakan lingkungan (iklim) yang sesuai utk pertumbuhan jamur?



Figure 5. Dimension of harvested oyster mushroom

The hardness test per fruit and the moisture content of the mushrooms were carried out by comparing the mushrooms on organic media and non-organic media on the FRP house with the housing at the farm level as shown in Table 4, indicating that the mushrooms in the model FRP house were harder and less water content than that ones in the farmer mushroom's housing at the farm level.

**Commented [NN21]:** ??? (jamur apakah golongan buah)

**Commented [NN22]:** Kok jadi membingungkan. Jika media organic dan non organic ini perlakuan, mestinya dijelaskan dalam metode. Apakah benar jamur di tingkat petani dibudidayakan secara non organic ?

**Commented [NN23]:** Mana data yang farm level?

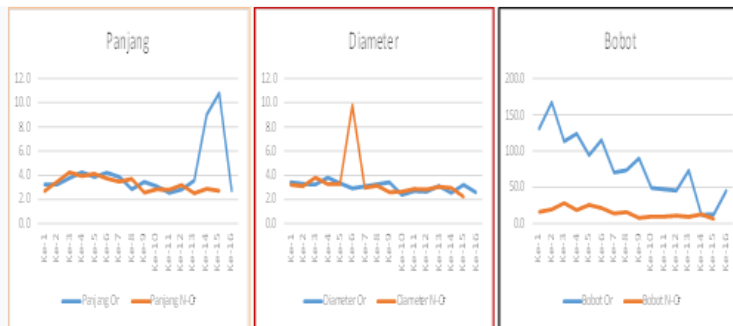

Figure 6 Dimension of fresh harvested mushroom

**Commented [NN24]:** Gambar ini tidak jelas dan juga tidak jelas untuk menjelaskan apa? Sumbu X tidak jelas. Resolusi gambar agar diperbaiki. Gambar ini mestinya bisa memberikan cerita lebih banyak.

**Commented [NN25]:** Ini data ornaik apa non organic?

**Commented [NN26]:** Apa satuannya?

Table 4. Characteristics of straw mushroom

No	Parameter	average
1.	texture	865,0±100,0
2	Dimension	
	- Length (mm)	41,5±6,0
	- Width (mm)	60,0±4,0
	- Height (mm)	29,5±9,0

### Micro Laboratory Analysis

The results of micro-laboratory analysis (Table 6) showed that the fresh harvested mushroom are negative from total fungus and salmonella

Tabel 5. Analysis result of total fungus and salmonella

Code	Phase of fungus	Total fungus (cfu/g)	Salmonella (negative/25g)
A	Non organic mushroom, Bloom	$2.9 \times 10^5$	negative
B	Non organic mushroom, fresh	$1.0 \times 10^5$	negative
C	Organic mushroom, bloom	$3.5 \times 10^4$	negative
D	Organic mushroom, fresh	$6.5 \times 10^4$	negative
E	non organic mushroom, bloom	$1.7 \times 10^6$	negative
F	non organic, mushroom, fresh	$5.4 \times 10^4$	negative

**Commented [NN27]:** Apa arti kode ABCD? Tabel (dan Gambar) adalah alat bantu untuk menjelaskan sesuatu. Tabel ini untuk menjelaskan apa? Berikan pembahasan yang memadai. Mushroom jamur Fungus juga jamur. Apa bedanya?

### Extraction of the Active Compound Ergothioneine

The results of the analysis on functional compounds of EGT in oyster mushrooms using the HPLC method, a graphic recording of the results of HPLC analysis of dried mushrooms with standard ethanol solvent. The average recording results from the EGT chromatography results were 0,674 mg/g as shown in Table 6

Tabel 6. Results of chromatogram graphic data processing from mushroom extract

Code	Area	Intercept	Slope	V (ml)	fp	B.s (g)	C (ppm)	C (%)	mg/g DW
Organic, et 70%	2,005	0,1501	0,0643	20	250	0,2006	719032,64	71,90	0,799
	2,0309	0,1501	0,0643	20	250	0,2006	729072,50	72,91	0,810
Non organic, et 70%	2,2289	0,1501	0,0643	20	250	0,2688	601370,99	60,14	0,668
	2,2626	0,1501	0,0643	20	250	0,2688	611119,98	61,11	0,679
Ethanol 96%	2,2255	0,1501	0,0643	20	250	0,2034	793432,33	79,34	0,882
	2,0676	0,1501	0,0643	20	250	0,2034	733066,64	73,31	0,815
Powder, organic	1,3702	0,1501	0,0643	20	250	0,2022	469216,53	46,92	0,521
	1,3862	0,1501	0,0643	20	250	0,2022	475369,69	47,54	0,528
Powder, anorganic	1,3431	0,1501	0,0643	20	250	0,2009	461763,43	46,18	0,513
	1,2709	0,1501	0,0643	20	250	0,2009	433817,65	43,38	0,482

**Commented [NN28]:** Apa arti nilai rata2 ini? Bisakah diambil rata2 dari jenis analisis dan jenis budidaya yang berbeda?

**Commented [NN29]:** Tabel ini untuk menjelaskan apa to? Metode ekstraksi? Jenis mushroom (organic/non organic)? Jenis bahan (powder/liquid)? Semua?

**Commented [NN30]:** Apa arti et 70%? Apa fp? Apa B.S? Apa C? Apa arti Code? (Mestinya ada di Metode penelitian) Tabel harus bersifat "self explaining". Yang tidak jelas harus ditambahkan penjelasan di bawah table. Tidak perlu masuk dalam table karena nilainya sama semua: Intercept Slope V Fp (ke 4 bisa dikeluarkan dari table, dan cukup dinarasikan dalam teks)

The extraction process breaks down the bonds among the molecules of the material so that EGT and phenol compounds are produced with varying concentrations depending on the type of solvent used (Table 7). The results of the standard solution analysis showed that the EGT compound had a retention time of  $3.33 \pm 0.06$  minutes, while the mushroom sample showed a retention time of 3.28 to 3.30 minutes.

Table 7. Recapitulation of EGT characterization data from edible mushrooms

Solvent	Concentration EGT (mg/g DW)	Total Phenol (mg/g DW)
Ethanol 96%	0,805 ± 0.01	0,015 ± 0.00
Ethanol 70%	0,848 ± 0.05	0,025 ± 0.00

**Commented [NN31]:** Jika sudah dirata2kan pada Tabel 6, mengapa di sini dibahas tersendiri? Bagaimana dengan yang powder organic dan non organic?

The extraction process using 70% ethanol produced higher concentrations of EGT and phenol than the extraction process using 96% ethanol. This shows that 70% of ethanol solvent is more effective used to bind EGT and phenol compounds in oyster mushrooms than that in pure solvents. This result is in line with the previous study conducted by Nguyen et al. (2012). The process of extracting the *Flammulina velutipes* mushroom using 70% ethanol was able to produce EGT and phenol compounds with higher concentrations than that the extraction using 50% and 100% of ethanol, with values of  $2.05 \pm 0.18$  mg/g and  $3.65 \pm 0,08$  DW, consecutively.

The extraction process that has been carried out can break down the bonds between the molecules of the material so that EGT and phenol compounds are produced with varying concentrations depending on the type of solvent used (Table 8). The results of the standard solution analysis showed that the EGT compound had a retention time of  $3.33 \pm 0.06$  minutes, while the straw mushroom sample showed a retention time of 3.28 to 3.30 minutes.

**Commented [NN32]:** Apa hubungan kalimat ini dengan Tabel 8. Mestinya dibahas Tabel 8, lalu diambil kesimpulan metode mana yang (bagus?) direkomendasikan.

Table 8. Methods and varying concentrations type of solvent for EGT

Species of mushroom	Methods	Concentration Ergothioneine (mg/g BK)
<i>Flammulina velutipes</i> Ref.: Nguyen et al. (2012)	water	$1.50 \pm 0.21$
	Ethanol 70%	$2.05 \pm 0.18$
	Methanol 70%	$1.86 \pm 0.04$
	Acetone 70%	$1.92 \pm 0.07$
<i>Pleurotus eryngii</i>	Hot water	0.86
<i>Pleurotus citrinopileatus</i>	Ref.: Yen et al. (2018)	3.73
<b>Oyster Mushroom</b>	<b>Ethanol 70%</b>	<b><math>0.67 \pm 0.01</math></b>

The extraction process for active compounds (Table 9), such as EGT and phenol, is influenced by several factors, such as solvent polarity and process conditions. A mixture of solutions has the ability to bind the active compound better than the pure solvent. This is due to the mixing of nonpolar solvents with water which can increase the polarity index of the solvent so that the extraction efficiency increases.

In addition, the increase in extraction temperature was positively correlated to the increase in antioxidant activity and polyphenols (flavonoids and total phenol), while the increase in extraction time was not positively correlated to the increase in antioxidant activity and polyphenols. In addition, the presence of agitation during the extraction process also

contributes to increasing the extraction yield. This happens because the agitation process can increase the rate of diffusion and minimize the barriers to mass transfer from the solid surface into the solution (Muhamad et al., 2014).

**Table 9.** the results of chromatograph analysis of mushroom samples

Code	Area	V (ml)	fp	B.s (g)	C (ppm)	C (%)
Organic	2,005	20	250	0,20	719032,6	71,90
Non organic	2,2289	20	250	0,27	601371,0	60,14
Ethanol 96%	2,2255	20	250	0,20	793432,3	79,34
Flour (organic)	1,3702	20	250	0,20	469216,5	46,92
Flour (unorganic)	1,3431	20	250	0,20	461763,4	46,18

**Commented [NN33]:** Apa bedanya Tabel ini dg Tabel 6. Jika ada hubungan harusnya Tabel 7 sehingga pembahasan tidak meloncat. Gunakan istilah yang konsisten flour atau powder (pilih salah satu)

Table 10 showed that the role in synthesizing EGT is the methyltransferase enzyme which is encoded by the EGT gene and specifically remodels histidine into EGT compounds (Stampfli et al., 2020). The results of another study stated that the biosynthesis of EGT is a complex synthesis process involving various types of amino acids and carbon sources. However, in principle there are three types of amino acids that play an important role in EGT biosynthesis, namely methionine, histidine, and cysteine. Histidine acts as a starting material that plays a role in the whole series of EGT biosynthesis. Cysteine serves to provide a source of sulfur atoms, while methionine which contains the protein S-adenosyl-l-methionine (SAM) acts as a precursor in reactions involving methyl groups. In supporting its growth, cells can use dextrose, fructose, glycerol, maltose, and sucrose as carbon sources. A suitable carbon source for EGT biosynthesis is glycerol because it is able to maintain cells in a longer stationary growth phase. In the glycolysis cycle, glycerol is broken down into glycerol-3 phosphate by the enzyme glycerol kinase. Furthermore, glycerol-3 phosphate is broken down by the enzyme glyceraldehyde-3 phosphate dehydrogenase to glyceron-P which is then overhauled by triosephosphate isomerase to glyceraldehyde 3 phosphate (GAP). GAP acts as a precursor in the glycolysis process to produce pyruvic acid which will also be a substrate in the Krebs cycle. Consumption of large amounts of pyruvic acid can stimulate enzymatic reactions of amino acids to produce EGT (Yu et al., 2020).

**Table 10.** Concentration of ergothioneine in different species of mushroom.

Mushroom Species	Ergothioneine Content*	Mushroom Species	Ergothioneine Content*
<i>Fomitopsis pinicola</i>	0.07 ± 0.01	<i>Polyozellus multiplex</i>	0.51 ± 0.01
<i>Ganoderma applanatum</i>	0.06 ± 0.02	<i>Ramaria botrytis</i>	0.29 ± 0.03
<i>G. lucidum</i>	0.08 ± 0.02	<i>S. granulatus</i>	0.09 ± 0.03
<i>G. neo-japonicum</i>	0.07 ± 0.00	<i>Lampteromyces japonicus</i>	0.43 ± 0.16

**Commented [NN34]:** Hasil penelitian Sdr masuk ke spesies apa dan berapa hasilnya? Mestinya dimasukkan dalam Tabel ini Beri satuan nya apa?

\*mg/g dw; Mean ± SD.

Sources: Modified from [Lee et al., 2009](#), [Ito et al., 2011](#).



## CONCLUSSION

The research results showed that the cultivation of oyster mushroom with a kumbung with ceramic floors and plastic walls and an IoT management. The temperature of the air inside was between 29 and 35 degrees Celsius, and the relative humidity was between 60% and 90%. The weight of fresh oyster mushroom was 865 mg. The length, width, and height of the fresh mushroom were measured to be 41.5 mm, 60.0 mm, and 29.5 mm, respectively. The microbiological test confirmed that there was no salmonella infection in the collected mushrooms. The stage of mushrooms have less total fungus than the bloom-stage mushrooms. The extraction standard method employs an EGT content of 0.674 mg/g as determined by chromatography data analysis. The oyster mushrooms can be consumed as a healthy meal, and the study of EGT showed also very prospective as one of immunotherapeutic food.

## REFERENCES

- Adiandri, R.S., Hidayah, N., dan Nugraha, S. 2018. Identification of amino acid, fatty acid, mineral content and respiration rate of straw mushroom in different stage of maturity. Proceeding the international seminar on tropical horticulture, 239-248
- Borodina, I., Kenny, L.C., McCarthy, C.M., Paramasivan, K., Pretorius, E., Roberts, T.J., van der Hoek, S.A, dan Kell, D.B. 2020. The biology of ergothioneine, an antioxidant nutraceutical. Nutrition Research Review, 33, 190-217
- Cheah, I.K., dan Halliwell, B. 2020. Could ergothioneine aid in the treatment of coronavirus patients? Antioxidants, 9, 595
- Dhalsamant, K., Dash, S.K., Bal, L.M., dan Panda, M.K. 2015. Effect of perforation mediated MAP on shelf life of mushroom (*Volvariella volvacea*). Scientia Horticulturae, 189, 41-50
- Halliwell, B., Cheah, I.K., dan Tang, R.M.Y. 2018. Ergothioneine – a diet-derived antioxidant with therapeutic potential. FEBS Letters, 592, 3357-3366
- Ito, T., Kato, M., Tsuchida, H., Harada, E., Niwa, T., dan Osawa, T. 2011. Ergothioneine as an anti-oxidative/anti-inflammatory component in several edible mushrooms. Food Sci. Technol. Res., 17(2), 103-110
- Jamjumroon, S., Wongs-Aree, C., McGlasson, W.B., dan Sriloang, V. 2012. Extending the shelf-life of straw mushroom with high carbon dioxide treatment. Journal of Food Agriculture and Environment, 10(1):78-84
- Kalaras, M.D., Richi, J.P., Calcagnotto, A., dan Beelman, R.B. 2017. Mushrooms: a rich source of the antioxidants ergothioneine and glutathione. Food Chemistry, 233, 429-433
- Kopinski, L., dan Kwiatkowska-Marks, S. 2012. Utilization of waste newspaper using oyster mushroom mycelium. Industrial & Engineering Chemistry Research, 51, 4440-4444
- Nguyen, T.H., Nagasaka, R., dan Ohshima, T. 2012. Effects of extraction solvents, cooking precedures and storage conditions on the contents of ergothioneine and phenolic compounds and antioxidative capacity of cultivated mushrooms *Flammulina velutipes*. International Journal of Food Science & Technology, doi: 10.1111/j.1365-2621.2012.02959.x
- Nur Sakinah, M.J., Misran, A., Mahmud, T.M.M., Abdullah, S., dan Azhar, M. 2020. Evaluation of storage temperature, packing system and storage duration on

**Commented [NN35]:** Dimana Sdr membahas berat Jamur kok tiba2 muncul di pembahasan?

Mungkin berisi 3 al:

- Kinerja rumah jamur dan system kontrolnya
- Karakteristik jamur (dimensi, kandungan kimia)
- Jamur sebagai Fungsional food.

**Commented [NN36]:** •Minimal 20 entry dari jurnal saja, selebihnya boleh dari buku, standard, Statistik, Laporan, Thesis.

• Tulis sesuai style JTEP (download paper JTEP terakhir dan lihat style nya sampai ke Pernik-pernik: nama, tahun dalam kurung, judul jurnal, tanda baca, DOI, cetak miring....)

• Yang disitasi harus dilist, yang dilist harus ada di sitasi.

• Jika memungkinkan Sdr diminta mensitasi paper JTEP yang relevan.

- postharvest quality of straw mushroom (*Volvariella volvacea*). *Food Research*, 4(3), 679-689
- Pahila, J., Ishikawa, Y., dan Ohshima, T. 2019. Effects of ergothioneine-rich mushroom extract on the oxidative stability of astaxanthin in liposomes. *Journal of Agricultural and Food Chemistry*, 67, 3491-3501
- Repine, J.E., dan Elkins, N.D. 2012. Effect of ergothioneine on acute lung injury and inflammation in cytokine insufflated rats. *Preventive Medicine*, 54, S79-S82
- Shinozaki, Y., Furuichi, K., Toyama, T., Kitajima, S., Hara, A., Iwata, Y., Sakai, N., Shimizu, M., Kaneko, S., Isozumi, N., Nagamori, S., Kanai, Y., Sugiura, T., Kato, Y., dan Wada, T. 2017. Impairment of the carnitine/organic cation transporter 1-ergothioneine axis is mediated by intestinal transporter dysfunction in chronic kidney disease. *Kidney Int.*, 92(6), 1356-1369
- Song, T.Y., Lin, H.C., Chen, C.L., Wu, J.H., Liao, J.W., dan Hu, M.L. 2014. Ergothioneine and melatonin attenuate oxidative stress and protect against learning and memory deficits in C57BL/6J mice treated with D-galactose. *Free Radic Res.*, 48(9), 1049-60
- Yoshida, S., Shime, H., Matsumoto, M., Kasahara, M., dan Seya, T. 2019. Anti-oxidative amino acid L-ergothioneine modulates the tumor microenvironment to facilitate adjuvant vaccine immunotherapy. *Front Immunol.*, 10, 671

## REVISI REVIEWER 2 :

### Exploration of Oyster Mushrooms for Functional Fresh Food

**Abstract.** This article presents studies on the physicochemical quality of oyster mushrooms grown within a housing and controlled by the Internet of Things (IoT). The goals of this study were to assess (1) the impact of indoor air quality on the growth and quality of mushrooms and (2) the antioxidant content of oyster mushrooms. In this study, the air temperature and humidity ~~per unit mass~~ of oyster mushroom per unit time will be recorded and automatically controlled by an IoT system. Additionally, their physicochemical and microbiological quality were evaluated using physico-analytical instruments, and the potency of their ergothioneine (EGT) content was investigated using the HPLC method. The **results showed that** temperature of the air inside was between 29 and 35 degrees Celsius, and the relative humidity was between 60% and 90%. The weight of fresh oyster mushroom was 865 mg. The length, width, and height of the fresh mushroom were measured to be 41.5 mm, 60.0 mm, and 29.5 mm, respectively. The microbiological test confirmed that there was no salmonella infection in the collected mushrooms. The button-stage mushrooms have less total fungus than the bloom-stage mushrooms. The extraction standard method employs an EGT content of 0.674 mg/g as determined by chromatography data analysis. The oyster mushrooms can be consumed as a healthy meal, and the study of EGT showed also very prospective as one of immunotherapeutic food.

Keywords: ergothioneine, Fibre-reinforced plastic house, Internet of think, oyster mushrooms

### INTRODUCTION

The oyster mushroom is a type of mushroom that specifically grows in tropical countries such as Indonesia. oyster mushrooms are grown on aggregate media one of them is the paddy waste from the paddy cultivation. Therefore, generally at the rice production centre area mostly becoming the centre for mushrooms production. This can be correlated with the availability of biomass as the main growing media for mushroom.

Cultivating high quality of the mushrooms required high-quality seeds, the high-quality media resources as well as the optimal environment due to the mushrooms are sensitive to climate change. To fulfil the optimum condition for mushrooms cultivation, an adequate production house is required to be implemented by environment controller and high-quality safety materials for growing media and to avoid using industrial in order to produce free contaminant (Kopinski, and Kwiatkowska-Marks, 2012).

A prototype of Fiber Reinforced Plastic (FRP) house (Ridwan Rachmat and Horibe, 1999) is a proper construction for mushroom production housing, ~~and it is implemented with an Internet of things (IoT) based connected to various devices microcontroller.~~ The mushroom production house used IoT control system is to make it easier to monitor the air condition inside the house online by mean of displaying the value generated from the installed sensors inside the house. According to Shasha Asyarita & Ani Lestari [7], temperature and humidity in production house of mushrooms greatly affect the growth process of mushrooms. So that the mushrooms do not rot, brown and wilt, the humidity in the mushroom production house should not be too high or low, ranging from 75%-90% at the humidity level of the mushroom production house.

Research by Dhiya et al [5] who conducted an analysis of the efficiency of the edible mushroom stated that the growth of high consumption of mushrooms was due to the high protein content of edible mushrooms. The mushroom has good properties for the nutritional needs of the human body such as being rich in protein, vitamin C and various water-soluble vitamins (riboflavin, biotin and thiamine), fat (5.7%), carbohydrates (56,8%), amino acids,

**Commented [NN37]:** Secara konten naskah OK. Secara umum naskah POOR.

- Judul kurang mewakili isi
- Tidak Fokus
- Metode: poor
- Pembahasan: kurang dalam
- Bhs Inggris: Poor
- (Jika anda tidak yakin dg bhs Inggris, sebaiknya submit naskah bhs Indonesia saja. Reviewnya nggak ribet).

**Commented [B638R37]:** IPHYSICOCHEMICAL QUALITY OF OYSTER MUSHROOMS FOR FUNCTIONAL FOOD

**Commented [NN39]:** Apa maksudnya? Adakah Suhu dan Kelembaban per unit massa? Perbaiki dan perjelas

**Commented [B640R39]:** Delete the words" per unit mass

**Commented [NN41]:** °C

**Commented [B642R41]:** degrees Celsius change into °C

**Commented [NN43]:** Pada umur panen berapa haris?

**Commented [B644R43]:** After two weeks to 15 days

**Commented [NN45]:** Paragraf meloncat-loncat. Perlu ditata ulang:  
Paragraf 1 OK.  
Keunggulan (karakteristik) mushroom  
Data (statistic) produksi/konsumsi mushroom  
Syarat tumbuh dan budidaya mushroom yang baik.  
Peranan IOT dalam budidaya mushroom yang baik.  
Tujuan penelitian.

**Commented [B646R45]:** and it is

**Commented [NN47]:** Apa maksudnya?

**Commented [B648R47]:** And it is

unsaturated fats, essential minerals (sodium, potassium and phosphorus) and has a low calorific value [6].

Mushrooms contain various types of nutrients those are beneficial to the health of the human body, such as carbohydrates, proteins, and fats. Several types of essential nutrients found in edible mushrooms include amino acids (glutamic acid, proline, phenylalanine, lysine, histidine, etc.), fatty acids (lauric, palmitic, oleic, lenoleic, etc.), potassium, calcium, and phosphorus (Adiandri et al., 2018). One type of essential amino acid found in mushrooms is ergothioneine (EGT). EGT is a derivative of histidine which contains functional groups of sulfur atoms and hydrogen atoms (-SH) and it can only be synthesized by fungi and actinobacteria (Borodina et al., 2020; Halliwell et al., 2018).

Mushrooms as a food source have been reported to have the highest level of ergothioneine compared to any other food source (Dubost et al., 2006, Dubost et al., 2007). In an early report, it has been shown that if we consume mushrooms as our regular food, the bioavailability of ergothioneine remains in our body (Weigand-Heller et al., 2012). The ergothioneine chemical compound is accumulated in the fruiting bodies as well as in the mycelia of the mushroom (Borodina et al., 2020, Kalaras et al., 2012). Several studies have been conducted with samples of mushrooms to describe improved ergothioneine production by the addition of several additives, such as aspartic acid, lysine, and methionine, which demonstrate increased ergothioneine biosynthesis (Lee et al., 2009). In addition, it has also been described that the production of ergothioneine increases with increased pH and is higher under alkaline conditions (Huang et al., 2015).

Research on the identification and isolation of EGT from several fungal varieties has been carried out. The content of EGT in mushrooms is quite high and has good antioxidant activity. In addition, differences in genus and species of fungi have different chemical compositions contained in them so that it affects the proportion of EGT in mushrooms (Kalaras et al., 2017). The results of the literature study indicate that the identification and isolation of EGT from edible mushroom has never been done. Therefore, research to explore the opportunity to use edible mushroom as a source of EGT needs to be done.

The provision of production house that meets food safety requirements is absolutely necessary to produce safe oyster mushrooms for consumption. Meanwhile the technology development of this mushroom production that meets food safety standards for the isolation of ergothioneine as an antioxidant is a potential matter in exploration of mushroom is still limited. This paper describes the research results of the prototype of FRP house with the air condition variation inside the house and the effect of air condition against mushroom quality. The effect of the IoT implementation in controlling the air condition system as well as minimizing the human contact during oyster mushroom growing during cultivation periods, and to explore the value added of mushroom through the ergothioneine (EGT) analysis as the of antioxidant content in mushroom.

## MATERIAL AND METHODS

The scope of research includes (1) constructing a prototype of FRP house with IoT control system for oyster mushroom cultivation; (2) to evaluate the air condition variation inside the house and the effect of air condition against mushroom growth and quality; (3) Analysis of antioxidant content in mushroom. The materials and chemicals used in this research are analytical grade chemicals. The effectiveness of antioxidant properties on isolated EGT was measured by in vitro method.

**Commented [i-49]:** Sumber pustaka yang dibirui sdh dilengkapi dilist References

**Commented [NN50]:** Mohon disusun: Kapan dan dimana penelitian dilakukan (jika perlu berikan koordinat geografisnya). Deskripsi rumah jamur

**Commented [B651R50]:** The research was conducted 2022 at the field laboratory of Post Harvest Research Center

**Commented [B652R50]:** The research was conducted 2022 at the field laboratory of Post Harvest Research Center of IAARD

**Commented [NN53]:** Menjadi tidak fokus, kearah mana makalah ini: perancangan rumah jamur, kinerja rumah jamur, karakteristik jamur. Nomor (1) dan (2) jadikan 1 dengan focus pada kinerja system control rumah jamur.

**Commented [i-54]:** The scope of this research focuses on the performance of the mushroom house control system.

**FRP House**

The FRP house built in a prototype scale (Figure 1) at an area of 650 cm x 350 cm with a light steel alloy as the frames and the roof is covered by a thin metal sheet and all the wall blanketed by fibre reinforced plastic (FRP), and white tile's floor, there are two shelves at inside the FRP house with two racks of 400 cm length and 100 cm width respectively.



Figure 1. Prototype of FRP house model of straw mushroom

Commented [NN55]: Berikan dimensi utama

Commented [B656R55]: 3,0 m x 5,0 m x 3,0 m

The FRP House implemented with an Internet of Think (IoT) system (Figure 2) to actuate a set of devices to measure the parameters of air temperature, air humidity, moisture content of the media. The control devices are 30 nozzles of mist sprayer setup along the rack of shelves above the media which are connected with a special hose. Hot air temperatures above 35°C, caused the exhaust fan is on, whenever a drastic drop of air temperature inside the FRP house below 29°C, thus the heater mixer will operate automatically to increase the room temperature. The controller specification showed in Table 1 are set at day and night time with the elapsed time of intervals are enable to monitor the parameters conditions to avoid disturbance during mushrooms growth.

Commented [i-57]: Mixer is delated

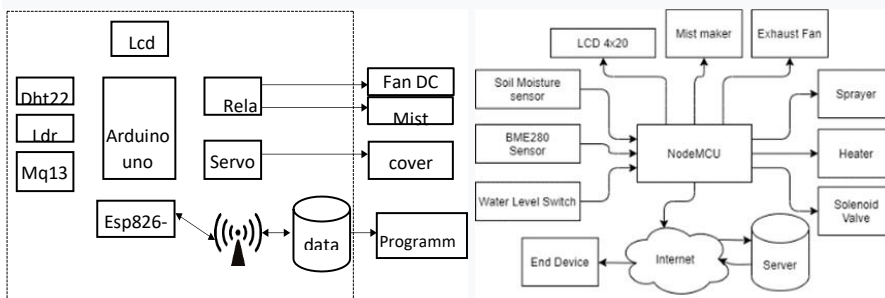

Figure 2. Architecture of IoT of production house in oyster mushroom

Commented [NN58]: Semua komponen gambar diinggriskan Beberapa nama komponen terpotong.

Commented [B659R58]: Cover....programm

The Arduino Node MCU is an open-source platform based on IoT, which is able to implement various commands with programming languages. The application of the C programming language uses a sketch on the Arduino IDE (Integrated Development Environment), which is capable of programming various kinds of microcontrollers including

Node MCU. The Node MCU has a small size compared to Arduino UNO, by using the ESP8266 module, there are GPIO (General-purpose input/output), PWM (Pulse Width Modulation), I2C, UART (Universal Asynchronous Receiver Transmitter), 1-Wire and ADC (Analog) to Digital Converter).

**Table 1.** Component and specification of control system every 20 minutes.

Component	Specifications
Sensor BME280	Air temperature and Humidity sensor
Soil Moisture sensor	Soil moisture content controller
Water Level sensor	Water height controller
Mist-maker	Fog production and controller
Exhaust fan	Air humidity controller
Arduino IDE 1.8.9, Fritzing	temperature and Humidity

**Commented [NN60]:** Tambahkan 1 kolom untuk frekwensi sensor itu melakukan pengambilan data (tiap berapa menit/jam/hari)

**Commented [B661R60]:** Every 20 minutes

### Cultivation Process Procedure

Mushroom cultivation process procedure was carried out inside FRP House and utilized the organic components which are mixed and fermentation process for 4 days to bea compost, and then fill into bag log evenly in a plastic sacks assembled inside FRP House. The layers of compost were pasteurized inside FRP house with closed cover condition tightly and then fogging with hot air at temperature 60-65°C for 8 hours. The mushroom seeds were inside over the bag logs of compost and then to be incubated for 3 days at around 29-30°C of inside air temperature. The treatment during mushroom growth up to harvest periods comprised of the inside air temperature, humidity by thermos hygrograph and soil water content sensor at every 20 minutes. The first harvesting conducted two weeks after seedling where the growth mushroom head is indicated by brownish head.

**Commented [NN62]:** Pengukuran suhu dan RH menggnakan alat dilakukan tiap berapa jam/hari? Jelaskan kapan panen dilakukan? (umur, atau ukuran)

**Commented [B663R62]:** The first harvesting conducted two weeks after seedling where the growth mushroom head is indicated by brownish head.

**Commented [NN64]:** Apakah ini satu parameter ini memadai untuk menilai Fungsional Food? Jika ya, berikan penekanan.

**Commented [B665R64]:** Ergothioneine is complex compound of antioxidant

### Extraction of the Active Compound Ergothioneine

Ergothioneine is complex compound of antioxidant. The isolation of ergothioneine EGT compounds from the harvested fresh mushrooms was carried out by the extraction method refers to the method developed by Ito et al. (2011) and Nguyen et al. (2012) with some modifications. Pre-treatment (blanching and non-blanching), mushroom before drying methods by electric oven drying.

The experimental factors of extraction employed the temperature 40°C and 60°C respectively with the variation of the extraction solvent (water and ethanol 30% (v/v), 50% (v/v), 70% ethanol (v/v), and ethanol 100 % (v/v)). The extraction procedure utilized 10 grams of dry mushroom powder and 200 mL of solvent which has been heated in a shaking water bath according to variations in temperature. The solvent along with the solute was continuously agitated at 100 rpm for 1 hour, then cooled at room temperature for 2 hours. Then it was centrifuged at 600 rpm for 15 minutes at 25°C. The achieved of the process is supernatant which was transferred to a conical tube for further evaporation using a vacuum evaporator at a temperature of 40°C to evaporate the remaining solvent up to be a paste of EGT extract. Furthermore, the paste of EGT was dried by the freeze-drying method. The dried EGT sample was then weighed to measure as the extraction yield.

### EGT concentration analysis

Analysis of the concentration of EGT in the oyster mushroom extract used the HPLC method referring to the method used by Kalaras et al. (2017) with some modifications. The mushroom powder (0.5 g) and 7 ml of ethanol was put into a 15 ml centrifuge tube (consisting

**Commented [NN66]:** Apa ini = ethanol? Atau sesuatu yang bersifat ethanol?

**Commented [B667R66]:** Ethanol (mistype---corrected

of 10 mM dithiothreitol, 100 M betaine, 100 M 2-mercapto-1-methyl imidazole) and 3 ml of distilled water was added and homogenized with a vortex for 10 seconds. A total of 2 mL of 1% SDS solution dissolved in ethanol was added and homogenized with a vortex for 10 seconds. Then the suspension was centrifuged for 20 minutes at 4000 rpm and 25°C. The supernatant formed was transferred to a 15 mL centrifugation tube. Then, 1 mL of the supernatant was put into a micro tube and allowed to stand for 24 hours. The solid formed from this process is then dissolved into 0.5 mL of aqua bides and homogenized using a vortex until it dissolves completely. Samples that have been stored in micro-tubes were centrifuged at 10,000 rpm for 1 minute. The supernatant formed was then filtered using a syringe filter (0.45 100 m) and put into a glass vial for HPLC analysis.

HPLC analysis was performed using column C18. The volume of the solution injected was 10 µL. The mobile phases used mobile phase A (3% acetonitrile, 0.1% TEA, 50 mM dibasic sodium phosphate dissolved in distilled water), mobile phase B (acetonitrile), and mobile phase C (water). The separation was performed on the elution gradient as follows: 0 minutes 15:85 (B:C), 0-5 minutes set at a slope of 5:15:85 (A:B:C), 5-6 minutes set at a slope of 10:90 (B:C), 6-8 minutes at 3:97 (B:C), and 8-15 at 3:97 (B:C). EGT was detected at a wavelength of 254 nm with a peak retention time of 5.7 min which was quantified using an external standard curve.

The antioxidant activity of EGT from edible mushroom was carried out by measuring the radical scavenging activity of DPPH referring to the method of Pahila et al. (2019). The analytical procedure comprised of 50 L of straw mushroom extract is added to 50 L of DPPH solution (100 M in 85% ethanol) and stirred using a vortex. After 15 minutes, the solution mixture was put into a 50 L Pyrex NMR capillary tube, then the DPPH radical spin resonance was measured with a spectrometer at a wavelength of 517. The spectrometer settings as microwave power, 1.2 mW; microwave frequency 9149.3 MHz; field magnet, 325.5 25 mT; and the sweep time, 30 seconds. Various concentrations of EGT were measured for resonance to construct a standard curve. The radical scavenging activity of DPPH was expressed as mmol equivalent of EGT per mL of sample.

## RESULTS AND DISCUSSION

### FRP House

The prototype of the FRP house is shown in Figure 3. Condition of the air temperature, air humidity and water content of the media inside the FRP house during mushroom cultivation are monitored automatically. The variation of air temperature around 29-39°C is relatively stable, while condition at day, night and rainy, resulted in high fluctuated of air humidity 40-98% with the water content of the media around 39-99%.

The devices inside the mushroom's FRP house consists of circuits, input blocks and output blocks which are joint by the Nodemcu microcomputer to control the air condition inside mushroom's FRP house. The input block is a soil moisture sensor and BME280 as a temperature, humidity and barometric detector. The sensor will generate an input value for the Nodemcu microcomputer, this value will be processed by Nodemcu which produces an output value to the connected devices. While the output block is a receiver a value generates by sensor through Nodemcu, such as a heater will operate if the temperature inside the mushroom's FRP house is low and the mist-maker will turn off if the humidity inside the mushroom's FRP house is sufficient. Nodemcu has a Wi-Fi module that is able to save the values and data in the database, this can make it easier to use a smartphone to access mushroom's FRP house condition even the values or data remotely. The IoT control system is setup for operating the hot air

**Commented [NN68]:** Sebaiknya pembahasan dipilah jadi 3 sub: Kinerja rumah jamur dan system kontrolnya  
Karakteristik jamur (dimensi),  
Karakteristik Jamur yang berkaitan dg Fungsional food.

**Commented [B669R68]:** The interaction of the parts are closed so All should be integrated in explanation

**Commented [NN70]:** Bagian ini mestinya membahas bagaimana kinerja rumah jamur terutama mengenai sensor dan system kontrolnya.  
Apakah berfungsi dengan baik?

exhaust with the mist sprayer process taking place in parallel if the air temperature at above 39°C with humidity below 60%. And when the opposite condition occurred (below 29°C), thus the water heater will actively operate spraying hot air vapor into the FRP House. This methods of IoT control mechanism will reduce the human intervention so that the growth process of mycelium and pinhead of fungal embryos can achieve optimally.

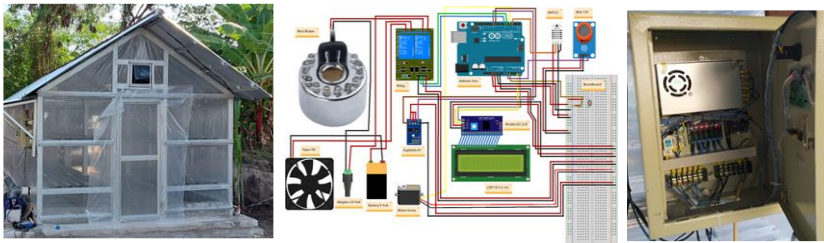

Figure 3. The prototype of the FRP house with IoT circuit

The generated measuring instrument and sensors performance corresponded the proposed elapsed time through the interface to display's monitor. In table 2 showed the comparison of sensor values with measuring instruments. Digital measuring instrument used to compare sensor values such as Hygrometer, lux meter and the average temperature difference of 0.92 °C and humidity of 2.1%.

Table 2. Temperature and humidity sensor testing

Temperature			Humidity		
Sensor	Device	Diff	Sensor	Device	Diff
31.7	30.8	0.9	77	76	1
31.6	30.7	0.9	78.3	77	1.3
31.7	30.7	1	78.9	78	0.9
31.8	30.7	1.1	78.3	78	0.3
31.8	30.7	1.1	79.1	79	0.1
31.8	31.3	0.5	80.2	79	1.2
32.2	31.1	1.1	83.4	82	1.4
32.2	31.2	1	82	82	0
32.1	31.5	0.6	81.3	81	0.3
32.1	31.1	1	81.2	81	0.2

Table 3 is a comparison graph of sensor values with measuring instruments. Digital measuring tools used to compare sensor values such as mini-Hygrometer, lux meter and carbon detector. The test was carried out by taking samples 30 times by getting an average temperature difference of 0.91 °C, humidity 0.89%. Furthermore, the light sensor gets an average difference of 19.76% and gas content of 10.13 ppm. The second test evaluates the performance of the tool and obtains an accuracy rate of success of 93.3%.

**Commented [NN71]:** Dari mana? Tabel 2 tital diff 9.2 dari 10 data (rata-rata 0.92)  
Sedangkan Diff RH lebih kecil lagi  
???  
Berapa kali pengambilan data (30?)  
Mengapa yang ditampilkan Cuma 10?

**Commented [B672R71]:** Mistype in units the correct one is 0,92

**Commented [NN73]:** Mengapa data yang disajikan Cuma 10?

**Commented [B674R73]:** This the sample that the sensor works

**Commented [i-75]:** Corrected 0C to °C



Table 3. Light sensor and CO<sub>2</sub> content

light			Gas Content		
Sensor	Device	Diff	Sensor	Device	Diff
192	175	17	21	10	11
187	144	43	33	12	21
182	152	30	16	9	7
103	100	3	24	16	8
170	145	25	22	20	2
-	-	-	-	-	-
-	-	-	-	-	-
144	124	20	18	7	11
169	123	46	10	3	7
118	115	3	15	8	7
124	121	3	24	16	8
128	122	6	30	20	10

**Effect of FRP House to Mushroom quality**

Air conditions and lighting inside mushroom's FRP house day and night during the mushroom growth (Figure 4) contribute for the effect to the quality of harvested fresh mushroom. The results of quality analysis indicated that the range of phenotype length of 2.5-10 cm, diameter of 3-10 cm and weight 10-120 gram (Figure 5), in general the mushrooms growth from organic media are longer and heavier than non-organic growth media with more uniform dimensions except for the diameter of phenotype and the harvesting period start at the 15<sup>th</sup> day and longer harvesting frequency within period up to 2 month.



Figure 4. Condition of air temperature, RH, and moisture content inside FRP House

**Commented [NN76]:** Jelaskan umur panen berapa hari? Bahaslah apakah ukuran ini normal, super, atau kecil?

**Commented [B677R76]:** the harvesting period start at the 15th day and longer harvesting frequency within period up to 2 month.

**Commented [NN78]:** Gambar ini mestinya digunakan untuk membahas kinerja rumah jamur dan fungsi sensor dan kontrolnya. Apakah rumah jamur berfungsi dengan baik, yaitu memberikan lingkungan yang sesuai dengan kebutuhan untuk pertumbuhan jamur. Apakah system control bekerja dengan baik, yaitu menciptakan lingkungan (iklim) yang sesuai utk pertumbuhan jamur?

**Commented [B679R78]:** This is to show the effect of air condition mentioned by sensors to the growth of the mushroom



Figure 5. Dimension of harvested oyster mushroom

The hardness test per fruit and the moisture content of the mushrooms were carried out by comparing the mushrooms on organic media and non organic media on the FRP house with the housing at the farm level as shown in Table 4, indicating that the mushrooms in the model FRP house were harder and less water content than that ones in the farmer mushroom's housing at the farm level.

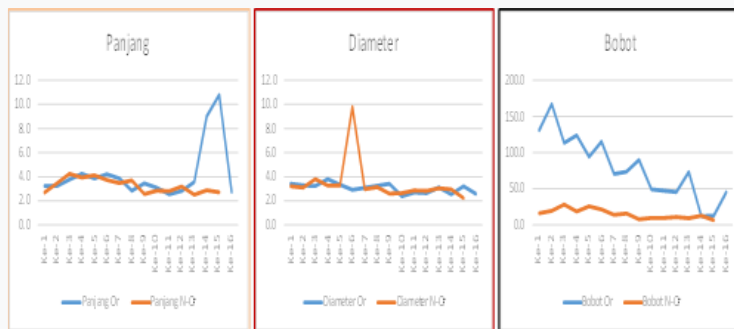

Figure 6 Dimension of fresh harvested mushroom

Table 4. Characteristics of straw mushroom

No	Parameter	average
1.	weight	865,0±100,0
2	Dimension	
	- Length (mm)	41,5±6,0
	- Width (mm)	60,0±4,0
	- Height (mm)	29,5±9,0

**Commented [NN80]:** ??? (jamur apakah golongan buah)

**Commented [B681R80]:** Non leafy vegetable

**Commented [NN82]:** Kok jadi membingungkan. Jika media organic dan non organic ini perlakuan, mestinya dijelaskan dalam metode. Apakah benar jamur di tingkat petani dibudidayakan secara non organic ?

**Commented [B683R82]:** It is not treatment, but it just to showed with other practices at other discussion

**Commented [B684R82]:** The words deleted

**Commented [NN85]:** Mana data yang farm level?

**Commented [NN86]:** Gambar ini tidak jelas dan juga tidak jelas untuk menjelaskan apa? Sumbu X tidak jelas. Resolusi gambar agar diperbaiki. Gambar ini mestinya bisa memberikan cerita lebih banyak.

**Commented [B687R86]:** To show the harvested mushroom dimension are higher than normal size

**Commented [NN88]:** Ini data ornaik apa non organic?

**Commented [B689R88]:** All data are in unorganic

**Commented [NN90]:** Apa satuannya?

**Commented [B691R90]:** Softness (kehalusan)

### Micro Laboratory Analysis

The results of micro-laboratory analysis (Table 6) showed that the fresh harvested mushroom are negative from total fungus and salmonella

Commented [i-92]: Table 5

Tabel 5. Analysis result of total fungus and salmonella

Code	Phase of fungus	Total fungus (cfu/g)	Salmonella (negative/25g)
A	Non organic mushroom, Bloom	2.9x10 <sup>5</sup>	negative
B	Non organic mushroom, fresh	1.0x10 <sup>5</sup>	negative
C	Organic mushroom, bloom	3.5x10 <sup>4</sup>	negative
D	Organic mushroom, fresh	6.5x10 <sup>4</sup>	negative
E	non organic mushroom, bloom	1.7x10 <sup>6</sup>	negative
F	non organic, mushroom, fresh	5.4x10 <sup>4</sup>	negative

Commented [NN93]: Apa arti kode ABCD? Tabel (dan Gambar) adalah alat bantu untuk menjelaskan sesuatu. Tabel ini untuk menjelaskan apa? Berikan pembahasan yang memadai. Mushroom jamur Fungus juga jamur. Apa bedanya?

Commented [B694R93]: code of samples

### Extraction of the Active Compound Ergothioneine

The results of the analysis on functional compounds of EGT in oyster mushrooms using the HPLC method, a graphic recording of the results of HPLC analysis of dried mushrooms with standard ethanol solvent. The average recording results from the EGT chromatography results were 0,674 mg/g as shown in Table 6

Commented [i-95]: Deleted

Table 6. Results of chromatogram graphic data processing from mushroom extract

Code	Area	Intercept	Slope	V (ml)	fp	B.s (g)	C (ppm)	C (%)	mg/g DW
Organic, et 70%	2,005	0,1501	0,0643	20	250	0,2006	719032,64	71,90	0,799
	2,0309	0,1501	0,0643	20	250	0,2006	729072,50	72,91	0,810
Non organic, et 70%	2,2289	0,1501	0,0643	20	250	0,2688	601370,99	60,14	0,668
	2,2626	0,1501	0,0643	20	250	0,2688	611119,98	61,11	0,679
Ethanol 96%	2,2255	0,1501	0,0643	20	250	0,2034	793432,33	79,34	0,882
	2,0676	0,1501	0,0643	20	250	0,2034	733066,64	73,31	0,815
Powder, organic	1,3702	0,1501	0,0643	20	250	0,2022	469216,53	46,92	0,521
	1,3862	0,1501	0,0643	20	250	0,2022	475369,69	47,54	0,528
Powder, anorganic	1,3431	0,1501	0,0643	20	250	0,2009	461763,43	46,18	0,513
	1,2709	0,1501	0,0643	20	250	0,2009	433817,65	43,38	0,482

Commented [NN96]: Apa arti nilai rata2 ini? Bisakah diambil rata2 dari jenis analisis dan jenis budidaya yang berbeda?

Commented [B697R96]: This is the initial results of EGT analysis.

Commented [NN98]: Tabel ini untuk menjelaskan apa to? Metode ekstraksi? Jenis mushroom (organic/non organic)? Jenis bahan (powder/liquid)? Semua?

Commented [NN99]: Apa arti et 70%? Apa fp? Apa B.S? Apa C? Apa arti Code? (Mestinya ada di Metode penelitian) Tabel harus bersifat "self explaining". Yang tidak jelas harus ditambahkan penjelasan di bawah table. Tidak perlu masuk dalam table karena nilainya sama semua: Intercept Slope V Fp (ke 4 bisa dikeluarkan dari table, dan cukup dinarasikan dalam teks)

Commented [B6100R99]: Ok deleted

The extraction process breaks down the bonds among the molecules of the material so that EGT and phenol compounds are produced with varying concentrations depending on the type of solvent used (Table 7). The results of the standard solution analysis showed that the

EGT compound had a retention time of  $3.33 \pm 0.06$  minutes, while the mushroom sample showed a retention time of 3.28 to 3.30 minutes.

Table 7. Recapitulation of EGT characterization data from edible mushrooms

Solvent	Concentration EGT (mg/g DW)	Total Phenol (mg/g DW)
Ethanol 96%	$0,805 \pm 0.01$	$0,015 \pm 0.00$
Ethanol 70%	$0,848 \pm 0.05$	$0,025 \pm 0.00$

**Commented [NN101]:** Jika sudah dirata2kan pada Tabel 6, mengapa di sini dibahas tersendiri? Bagaimana dengan yang powder organic dan non organic?

The extraction process using 70% ethanol produced higher concentrations of EGT and phenol than the extraction process using 96% ethanol. This shows that 70% of ethanol solvent is more effective used to bind EGT and phenol compounds in oyster mushrooms than that in pure solvents. This result is in line with the previous study conducted by Nguyen et al. (2012). The process of extracting the *Flammulina velutipes* mushroom using 70% ethanol was able to produce EGT and phenol compounds with higher concentrations than that the extraction using 50% and 100% of ethanol, with values of  $2.05 \pm 0.18$  mg/g and  $3.65 \pm 0,08$  DW, consecutively.

The extraction process that has been carried out can break down the bonds between the molecules of the material so that EGT and phenol compounds are produced with varying concentrations depending on the type of solvent used (Table 8). The results of the standard solution analysis showed that the EGT compound had a retention time of  $3.33 \pm 0.06$  minutes, while the straw mushroom sample showed a retention time of 3.28 to 3.30 minutes.

**Commented [NN102]:** Apa hubungan kalimat ini dengan Tabel 8. Mestinya dibahas Tabel 8, lalu diambil kesimpulan metode mana yang (bagus?) direkomendasikan.

Table 8. Methods and varying concentrations type of solvent for EGT

Species of mushroom	Methods	Concentration Ergothioneine (mg/g BK)
<i>Flammulina velutipes</i> Ref.: Nguyen et al. (2012)	water	$1.50 \pm 0.21$
	Ethanol 70%	$2.05 \pm 0.18$
	Methanol 70%	$1.86 \pm 0.04$
	Acetone 70%	$1.92 \pm 0.07$
<i>Pleurotus eryngii</i>	Hot water	0.86
<i>Pleurotus citrinopileatus</i>	Ref.: Yen et al. (2018)	3.73
<b>Oyster Mushroom</b>	<b>Ethanol 70%</b>	<b><math>0.67 \pm 0.01</math></b>

The extraction process for active compounds (Table 9), such as EGT and phenol, is influenced by several factors, such as solvent polarity and process conditions. A mixture of solutions has the ability to bind the active compound better than the pure solvent. This is due to the mixing of nonpolar solvents with water which can increase the polarity index of the solvent so that the extraction efficiency increases.

In addition, the increase in extraction temperature was positively correlated to the increase in antioxidant activity and polyphenols (flavonoids and total phenol), while the

increase in extraction time was not positively correlated to the increase in antioxidant activity and polyphenols. In addition, the presence of agitation during the extraction process also contributes to increasing the extraction yield. This happens because the agitation process can increase the rate of diffusion and minimize the barriers to mass transfer from the solid surface into the solution (Muhamad et al., 2014).

**Table 9.** the results of chromatograph analysis of mushroom samples

Code	Area	V (ml)	fp	B.s (g)	C (ppm)	C (%)
Organic	2,005	20	250	0,20	719032,6	71,90
Non organic	2,2289	20	250	0,27	601371,0	60,14
Ethanol 96%	2,2255	20	250	0,20	793432,3	79,34
Flour (organic)	1,3702	20	250	0,20	469216,5	46,92
Flour (unorganic)	1,3431	20	250	0,20	461763,4	46,18

**Commented [NN103]:** Apa bedanya Tabel ini dg Tabel 6. Jika ada hubungan harusnya Tabel 7 sehingga pembahasan tidak meloncat. Gunakan istilah yang konsisten flour atau powder (pilih salah satu)

Table 10 showed that the role in synthesizing EGT is the methyltransferase enzyme which is encoded by the EGT gene and specifically remodels histidine into EGT compounds (Stampfli et al., 2020). The results of another study stated that the biosynthesis of EGT is a complex synthesis process involving various types of amino acids and carbon sources. However, in principle there are three types of amino acids that play an important role in EGT biosynthesis, namely methionine, histidine, and cysteine. Histidine acts as a starting material that plays a role in the whole series of EGT biosynthesis. Cysteine serves to provide a source of sulfur atoms, while methionine which contains the protein S-adenosyl-L-methionine (SAM) acts as a precursor in reactions involving methyl groups. In supporting its growth, cells can use dextrose, fructose, glycerol, maltose, and sucrose as carbon sources. A suitable carbon source for EGT biosynthesis is glycerol because it is able to maintain cells in a longer stationary growth phase. In the glycolysis cycle, glycerol is broken down into glycerol-3 phosphate by the enzyme glycerol kinase. Furthermore, glycerol-3 phosphate is broken down by the enzyme glyceraldehyde-3 phosphate dehydrogenase to glyceraldehyde-3 phosphate (GAP). GAP acts as a precursor in the glycolysis process to produce pyruvic acid which will also be a substrate in the Krebs cycle. Consumption of large amounts of pyruvic acid can stimulate enzymatic reactions of amino acids to produce EGT (Yu et al., 2020).

**Table 10.** Concentration of ergothioneine in different species of mushroom.

Mushroom Species	Ergothioneine Content*	Mushroom Species	Ergothioneine Content*
<i>Fomitopsis pinicola</i>	0.07 ± 0.01	<i>Polyozellus multiplex</i>	0.51 ± 0.01
<i>Ganoderma applanatum</i>	0.06 ± 0.02	<i>Ramaria botrytis</i>	0.29 ± 0.03
<i>G. lucidum</i>	0.08 ± 0.02	<i>S. granulates</i>	0.09 ± 0.03

**Commented [NN104]:** Hasil penelitian Sdr masuk ke spesies apa dan berapa hasilnya? Mestinya dimasukkan dalam Tabel ini Beri satuan nya apa?

**Commented [B6105R104]:** Ini sebagai referensi saja karena metode extraction yg berbeda

Mushroom Species	Ergothioneine Content*	Mushroom Species	Ergothioneine Content*
<i>G. neo-japonicum</i>	0.07 ± 0.00	Lampteromyces japonicus	0.43 ± 0.16

\*mg/g dw; Mean ± SD.

Sources: Modified from [Lee et al., 2009](#), [Ito et al., 2011](#).

### CONCLUSION

The research results showed that the cultivation of oyster mushroom with a FRP House with ceramic floors and plastic walls and an IoT management The temperature of the air inside was between 29 and 35 degrees Celsius, and the relative humidity was between 60% and 90%. The weight of fresh oyster mushroom was 865 mg/g. The length, width, and height of the fresh mushroom were measured to be 41.5 mm, 60.0 mm, and 29.5 mm, respectively. The microbiological test confirmed that there was no salmonella infection in the collected mushrooms. The stage of mushrooms have less total fungus than the bloom-stage mushrooms. The extraction standard method employs an EGT content of 0.674 mg/g as determined by chromatography data analysis. The oyster mushrooms can be consumed as a healthy meal, and the study of EGT showed also very prospective as one of immunotherapeutic food.

### REFERENCES

- Adiandri, R.S., Hidayah, N., dan Nugraha, S. 2018. Identification of amino acid, fatty acid, mineral content and respiration rate of straw mushroom in different stage of maturity. Proceeding the international seminar on tropical horticulture, 239-248
- Borodina, I., Kenny, L.C., McCarthy, C.M., Paramasivan, K., Pretorius, E., Roberts, T.J., van der Hoek, S.A. and Kell, D.B., 2020. The biology of ergothioneine, an antioxidant nutraceutical. Nutrition Research Reviews, 33(2), 190-217.
- Cheah, I.K., dan Halliwell, B. 2020. Could ergothioneine aid in the treatment of coronavirus patients? Antioxidants, 9, 595
- Dhalsamant, K., Dash, S.K., Bal, L.M., dan Panda, M.K. 2015. Effect of perforation mediated MAP on shelf life of mushroom (*Volvariella volvacea*). Scientia Horticulturae, 189, 41-50
- Dubost, N.J., Beelman, R.B., Peterson, D. and Royse, D.J., 2006. Identification and quantification of ergothioneine in cultivated mushrooms by liquid chromatography-mass spectroscopy. International Journal of Medicinal Mushrooms, 8(3).
- Halliwell, B., Cheah, I.K., dan Tang, R.M.Y. 2018. Ergothioneine – a diet-derived antioxidant with therapeutic potential. FEBS Letters, 592, 3357-3366
- Huang, X. and Nie, S., 2015. The structure of mushroom polysaccharides and their beneficial role in health. Food & function, 6(10), 3205-3217.
- Ito, T., Kato, M., Tsuchida, H., Harada, E., Niwa, T. and Osawa, T., 2011. Ergothioneine as an anti-oxidative/anti-inflammatory component in several edible mushrooms. Food science and technology research, 17(2), 103-110.

**Commented [NN106]:** Dimana Sdr membahas berat Jamur kok tiba2 muncul di pembahasan?

Mungkin berisi 3 al:

- Kinerja rumah jamur dan system kontrolnya
- Karakteristik jamur (dimensi, kandungan kimia)
- Jamur sebagai Fungsional food.

**Commented [B6107R106]:** Ada di dimensi dan bobot dalam narasi sebagai table 4..bukan texture tapi weight of mushroom

- Commented [NN108]:** •Minimal 20 entry dari jurnal saja, selebihnya boleh dari buku, standard, Statistik, Laporan, Thesis.
- Tulis sesuai style JTEP (download paper JTEP terakhir dan lihat style nya sampai ke Pernik-pernik: nama, tahun dalam kurung, judul jurnal, tanda baca, DOI, cetak miring....)
  - Yang disitasi harus dilist, yang dilist harus ada di sitasi.
  - Jika memungkinkan Sdr diminta mensitasi paper JTEP yang relevan.

**Commented [B6109R108]:** Ok  
Sudah ada minimal 20 entry dari jurnal.  
Yang disitasi sudah ada di dilist, yang dilist sudah ada di sitasi

- Jamjumroon, S., Wongs-Aree, C., McGlasson, W.B., dan Sriloang, V. 2012. Extending the shelf-life of straw mushroom with high carbon dioxide treatment. *Journal of Food Agriculture and Environment*, 10(1):78-84
- Kalaras, M.D., Beelman, R.B., Holick, M.F. and Elias, R.J., 2012. Generation of potentially bioactive ergosterol-derived products following pulsed ultraviolet light exposure of mushrooms (*Agaricus bisporus*). *Food chemistry*, 135(2), 396-401.
- Kalaras, M.D., Richi, J.P., Calcagnotto, A., dan Beelman, R.B. 2017. Mushrooms: a rich source of the antioxidants ergothioneine and glutathione. *Food Chemistry*, 233, 429-433
- Kopinski, L., dan Kwiatkowska-Marks, S. 2012. Utilization of waste newspaper using oyster mushroom mycelium. *Industrial & Engineering Chemistry Research*, 51, 4440-4444
- Lee, S.H., Hwang, H.S. and Yun, J.W., 2009. Antitumor activity of water extract of a mushroom, *Inonotus obliquus*, against HT-29 human colon cancer cells. *Phytotherapy Research*, 23(12), 1784-1789.
- Nguyen, T.H., Nagasaka, R., dan Ohshima, T. 2012. Effects of extraction solvents, cooking procedures and storage conditions on the contents of ergothioneine and phenolic compounds and antioxidative capacity of cultivated mushrooms *Flammulina velutipes*. *International Journal of Food Science & Technology*, doi: 10.1111/j.1365-2621.2012.02959.x
- Nur Sakinah, M.J., Misran, A., Mahmud, T.M.M., Abdullah, S., dan Azhar, M. 2020. Evaluation of storage temperature, packing system and storage duration on postharvest quality of straw mushroom (*Volvariella volvacea*). *Food Research*, 4(3), 679-689
- Pahila, J., Ishikawa, Y., dan Ohshima, T. 2019. Effects of ergothioneine-rich mushroom extract on the oxidative stability of astaxanthin in liposomes. *Journal of Agricultural and Food Chemistry*, 67, 3491-3501
- Repine, J.E., dan Elkins, N.D. 2012. Effect of ergothioneine on acute lung injury and inflammation in cytokine insufflated rats. *Preventive Medicine*, 54, S79-S82
- Shinozaki, Y., Furuichi, K., Toyama, T., Kitajima, S., Hara, A., Iwata, Y., Sakai, N., Shimizu, M., Kaneko, S., Isozumi, N., Nagamori, S., Kanai, Y., Sugiura, T., Kato, Y., dan Wada, T. 2017. Impairment of the carnitine/organic cation transporter 1-ergothioneine axis is mediated by intestinal transporter dysfunction in chronic kidney disease. *Kidney Int.*, 92(6), 1356-1369
- Song, T.Y., Lin, H.C., Chen, C.L., Wu, J.H., Liao, J.W., dan Hu, M.L. 2014. Ergothioneine and melatonin attenuate oxidative stress and protect against learning and memory deficits in C57BL/6J mice treated with D-galactose. *Free Radic Res.*, 48(9), 1049-60
- Weigand-Heller, A.J., Kris-Etherton, P.M. and Beelman, R.B., 2012. The bioavailability of ergothioneine from mushrooms (*Agaricus bisporus*) and the acute effects on antioxidant capacity and biomarkers of inflammation. *Preventive Medicine*, 54, S75-S78.
- Yoshida, S., Shime, H., Matsumoto, M., Kasahara, M., dan Seya, T. 2019. Anti-oxidative amino acid L-ergothioneine modulates the tumor microenvironment to facilitate adjuvant vaccine immunotherapy. *Front Immunol.*, 10, 671

## 1b.6.c. GABUNGAN REVISI DARI REVIEWER 1 DAN 2

### Physicochemical Quality of Oyster Mushroom for Functional Food

**Abstract.** This article presents studies on the physicochemical quality of oyster mushrooms grown within a housing and controlled by the Internet of Things (IoT). The goals of this study were to assess (1) the impact of indoor air quality on the growth and quality of mushrooms and (2) the antioxidant content of oyster mushrooms. In this study, **the air temperature and humidity of oyster mushroom per unit time will be recorded and automatically controlled by an IoT system.** Additionally, their physicochemical and microbiological quality were evaluated using physico-analytical instruments, and the potency of their ergothioneine (EGT) content was investigated using the HPLC method. The temperature of the air inside was between 29 and 35 °C, and the relative humidity was between 60% and 90%. **The average weight of selected fresh oyster mushrooms was 865 mg. The average length, width, and height of the fresh mushroom were measured to be 41.5 mm, 60.0 mm, and 29.5 mm, respectively.** The microbiological test confirmed that there was no salmonella infection in the collected mushrooms. The button-stage mushrooms have less total fungus than the bloom-stage mushrooms. The extraction standard method employs an EGT content of 0.674 mg/g as determined by chromatography data analysis. The oyster mushrooms can be consumed as a healthy meal, and the study of EGT showed also very prospective as one of immunotherapeutic food.

Keywords: ergothioneine, Fibre-reinforced plastic house, Internet of think, oyster mushrooms

#### INTRODUCTION

The oyster mushroom is a type of mushroom that specifically grows in tropical countries such as Indonesia. **Oyster** mushrooms are grown on aggregate media one of them is the paddy waste from the paddy cultivation. Therefore, generally at the rice production centre area mostly becoming the centre for mushrooms production. This can be correlated with the availability of biomass as the main growing media for mushroom.

Cultivating high quality of the mushrooms required high-quality seeds, the high-quality media resources as well as the optimal environment due to the mushrooms are sensitive to climate change. To fulfil the optimum condition for mushrooms cultivation, an adequate production house is required to be implemented by environment controller and high-quality safety materials for growing media and to avoid using industrial in order to produce free contaminant (Kopinski, and Kwiatkowska-Marks, 2012).

A prototype of Fiber Reinforced Plastic (FRP) house (Ridwan Rachmat and Horibe, 1999) is a proper construction for mushroom production housing, **and it is** implemented with an Internet of things (IoT) based connected to various devices microcontroller. The mushroom production house used IoT control system is to make it easier to monitor the air condition inside the house online by mean of displaying the value generated from the installed sensors inside the house. According to Shasha Asyarita & Ani Lestari [7], temperature and humidity in production house of mushrooms greatly affect the growth process of mushrooms. So that the mushrooms do not rot, brown and wilt, the humidity in the mushroom production house should not be too high or low, ranging from 75%-90% at the humidity level of the mushroom production house.

Research by Dhiya et al [5] who conducted an analysis of the efficiency of the edible mushroom stated that the growth of high consumption of mushrooms was due to the high protein content of edible mushrooms. The mushroom has good properties for the nutritional needs of the human body such as being rich in protein, vitamin C and various water-soluble vitamins (riboflavin, biotin and thiamine), fat (5.7%), carbohydrates (56,8%), amino acids, unsaturated fats, essential minerals (sodium, potassium and phosphorus) and has a low calorific value [6].



Mushrooms contain various types of nutrients those are beneficial to the health of the human body, such as carbohydrates, proteins, and fats. Several types of essential nutrients found in edible mushrooms include amino acids (glutamic acid, proline, phenylalanine, lysine, histidine, etc.), fatty acids (lauric, palmitic, oleic, lenoleic, etc.), potassium, calcium, and phosphorus (Adiandri et al., 2018). One type of essential amino acid found in mushrooms is ergothioneine (EGT). EGT is a derivative of histidine which contains functional groups of sulfur atoms and hydrogen atoms (-SH) and it can only be synthesized by fungi and actinobacteria (Borodina et al., 2020; Halliwell et al., 2018).

Mushrooms as a food source have been reported to have the highest level of ergothioneine compared to any other food source ([Dubost et al., 2006](#), [Dubost et al., 2007](#)). In an early report, it has been shown that if we consume mushrooms as our regular food, the bioavailability of ergothioneine remains in our body ([Weigand-Heller et al., 2012](#)). The ergothioneine chemical compound is accumulated in the fruiting bodies as well as in the mycelia of the mushroom ([Borodina et al., 2019](#), [Kařaras et al., 2020](#)). Several studies have been conducted with samples of mushrooms to describe improved ergothioneine production by the addition of several additives, such as aspartic acid, lysine, and methionine, which demonstrate increased ergothioneine biosynthesis ([Lee et al., 2009](#)). In addition, it has also been described that the production of ergothioneine increases with increased pH and is higher under alkaline conditions ([Huang et al., 2015](#)).

Research on the identification and isolation of EGT from several fungal varieties has been carried out. The content of EGT in mushrooms is quite high and has good antioxidant activity. In addition, differences in genus and species of fungi have different chemical compositions contained in them so that it affects the proportion of EGT in mushrooms (Kalaras et al., 2017). The results of the literature study indicate that the identification and isolation of EGT from edible mushroom has never been done. Therefore, research to explore the opportunity to use edible mushroom as a source of EGT needs to be done.

The provision of production house that meets food safety requirements is absolutely necessary to produce safe oyster mushrooms for consumption. Meanwhile the technology development of this mushroom production that meets food safety standards for the isolation of ergothioneine as an antioxidant is a potential matter in exploration of mushroom is still limited. This paper describes the research results of the prototype of FRP house with the air condition variation inside the house and the effect of air condition against mushroom quality. The effect of the IoT implementation in controlling the air condition system as well as minimizing the human contact during oyster mushroom growing during cultivation periods, and to explore the value added of mushroom through the ergothioneine (EGT) analysis as the of antioxidant content in mushroom.

The scope of research includes (1) constructing a prototype of FRP house with IoT control system for oyster mushroom cultivation; (2) to evaluate the air condition variation inside the house and the effect of air condition against mushroom growth and quality; (3) Analysis of antioxidant content in mushroom.

## MATERIAL AND METHODS

The research was conducted 2022 at the field laboratory of Post Harvest Research Center of IAARD. The scope of this research focuses on the performance of the mushroom house control system. The materials used in this research are analytical grade chemicals. The effectiveness of antioxidant properties on isolated EGT was measured by in vitro method.

### FRP House

The FRP house constructed (Figure 1) at an area of 650 cm x 350 cm with a light steel alloy frames and the roof is covered by a thin metal sheet roof and all each the wall blanketed

by fibre reinforced plastic. (FRP), and white ceramic tile's floor. There are two shelves at inside the FRP house with of 400 cm length and 100 cm width respectively.

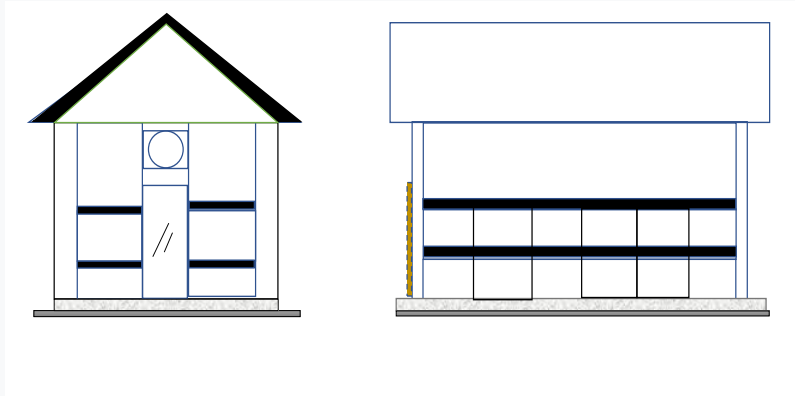

Figure 1. Prototype of FRP house model of straw mushroom (Dimentions 3,0 m x 5,0 m x 3,0 m)

The FRP House implemented with an Internet of Think (IoT) system (Figure 2) to actuate a set of devices to measure the parameters of air temperature, air humidity, moisture content of the media. The control devices are 30 nozzles of mist sprayer setup along the rack of shelves above the media which are connected with a special hose. Hot air temperatures above 35°C, caused the exhaust fan is on, whenever a drastic drop of air temperature inside the FRP house below 29°C, thus the heater will operate automatically to increase the room temperature. The controller specification showed in Table 1 are set at day and night time with the elapsed time of intervals are enable to monitor the parameters conditions to avoid disturbance during mushrooms growth.

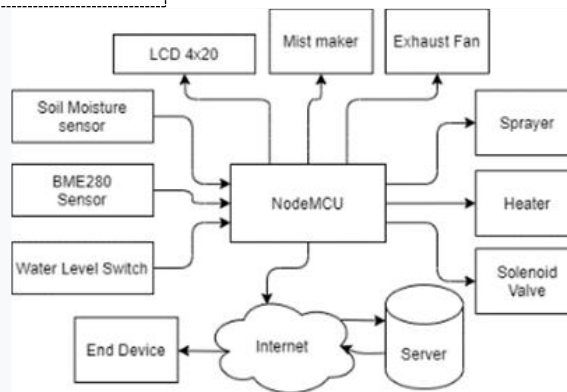
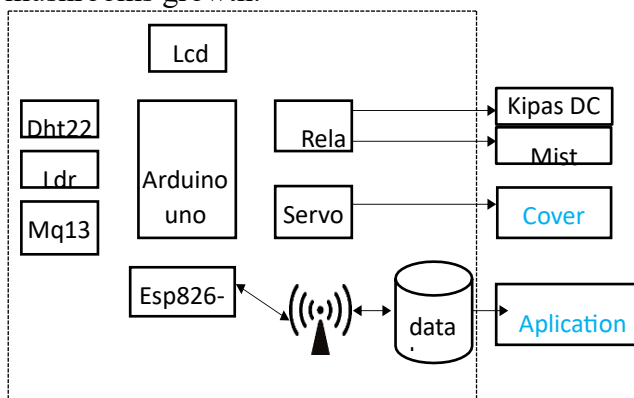

Figure 2. Architecture of IoT of production house in oyster mushroom

The Arduino Node MCU is an open-source platform based on IoT, which is able to implement various commands with programming languages. The application of the C programming language uses a sketch on the Arduino IDE (Integrated Development Environment), which is capable of programming various kinds of microcontrollers including Node MCU. The Node MCU has a small size compared to Arduino UNO, by using the ESP8266 module, there are GPIO (General-purpose input/output), PWM (Pulse Width Modulation), I2C, UART (Universal Asynchronous Receiver Transmitter), 1-Wire and **ADC (Analog to Digital Converter)**.

Table 1. Component and specification of control system [every 20 minutes](#)

Component	Specifications
Sensor BME280	Air temperature and Humidity sensor
Soil Moisture sensor	Soil moisture content controller
Water Level sensor	Water height controller
Mist-maker	Fog production and controller
Exhaust fan	Air humidity controller
<a href="#">Arduino IDE 1.8.9, fritzing</a>	<a href="#">Temperature and Humidity</a>

### Cultivation Process Procedure

Mushroom cultivation process procedure was carried out inside FRP House and utilized the organic components which are mixed and fermentation process for 4 days to be a compost, and then fill into bag log evenly in a plastic sacks assembled inside FRP House. The layers of compost were pasteurized inside FRP house with closed cover condition tightly and then fogging with hot air at temperature 60-65°C for 8 hours. The mushroom seeds were inside over the bag logs of compost and then to be incubated for 3 days at around 29-30°C of inside air temperature. The treatment during mushroom growth up to harvest periods comprised of the inside air temperature, humidity and soil water content. The treatment during mushroom growth up to harvest periods comprised of the inside air temperature, humidity by thermos hygrograph and soil water content sensor at every 20 minutes. [The first harvesting conducted two weeks after seedling where the growth mushroom head is indicated by brownish head.](#)

### Extraction of the Active Compound Ergothioneine

[Ergothioneine is complex compound of antioxidant.](#) The isolation of ergothioneine EGT compounds from the harvested fresh mushrooms was carried out by the extraction method refers to the method developed by Ito et al. (2011) and Nguyen et al. (2012) with some modifications. Pre-treatment (blanching and non-blanching), mushroom before drying methods by electric oven drying.

The experimental factors of extraction employed the temperature 40°C and 60°C respectively with the variation of the extraction solvent (water and ethanol 30% (v/v), 50% (v/v), 70% ethanol (v/v), and ethanol 100 % (v/v)). The extraction procedure utilized 10 grams of dry mushroom powder and 200 mL of solvent which has been heated in a shaking water bath according to variations in temperature. The solvent along with the solute was continuously agitated at 100 rpm for 1 hour, then cooled at room temperature for 2 hours. Then it was centrifuged at 600 rpm for 15 minutes at 25°C. The achieved of the process is supernatant which was transferred to a conical tube for further evaporation using a vacuum evaporator at a temperature of 40°C to evaporate the remaining solvent up to be a paste of EGT extract. Furthermore, the paste of EGT was dried by the freeze-drying method. The dried EGT sample was then weighed to measure as the extraction yield.

### EGT concentration analysis

Analysis of the concentration of EGT in the oyster mushroom extract used the HPLC method referring to the method used by Kalaras et al. (2017) with some modifications. The mushroom powder (0.5 g) and 7 ml of ethanol was put into a 15 ml centrifuge tube (consisting of 10 mM dithiothreitol, 100 M betaine, 100 M 2-mercapto-1-methyl imidazole) and 3 ml of distilled water was added and homogenized with a vortex for 10 seconds. A total of 2 mL of 1% SDS solution dissolved in ethanol was added and homogenized with a vortex for 10 seconds. Then the suspension was centrifuged for 20 minutes at 4000 rpm and 25°C. The supernatant formed was transferred to a 15 mL centrifugation tube. Then, 1 mL of the supernatant was put into a micro tube and allowed to stand for 24 hours. The solid formed from this process is then dissolved into 0.5 mL of aqua bides and homogenized using a vortex until it dissolves completely. Samples that have been stored in micro-tubes were centrifuged at 10,000 rpm for 1 minute. The supernatant formed was then filtered using a syringe filter (0.45 100 m) and put into a glass vial for HPLC analysis.

HPLC analysis was performed using column C18. The volume of the solution injected was 10  $\mu$ L. The mobile phases used mobile phase A (3% acetonitrile, 0.1% TEA, 50 mM dibasic sodium phosphate dissolved in distilled water), mobile phase B (acetonitrile), and mobile phase C (water). The separation was performed on the elution gradient as follows: 0 minutes 15:85 (B:C), 0-5 minutes set at a slope of 5:15:85 (A:B:C), 5-6 minutes set at a slope of 10:90 ( B:C), 6-8 minutes at 3:97 (B:C), and 8-15 at 3:97 (B:C). EGT was detected at a wavelength of 254 nm with a peak retention time of 5.7 min which was quantified using an external standard curve.

The antioxidant activity of EGT from edible mushroom was carried out by measuring the radical scavenging activity of DPPH referring to the method of Pahila et al. (2019). The analytical procedure comprised of 50 L of straw mushroom extract is added to 50 L of DPPH solution (100 M in 85% ethanol) and stirred using a vortex. After 15 minutes, the solution mixture was put into a 50 L Pyrex NMR capillary tube, then the DPPH radical spin resonance was measured with a spectrometer at a wavelength of 517. The spectrometer settings as microwave power, 1.2 mW; microwave frequency 9149.3 MHz; field magnet, 325.5 25 mT; and the sweep time, 30 seconds. Various concentrations of EGT were measured for resonance to construct a standard curve. The radical scavenging activity of DPPH was expressed as mmol equivalent of EGT per mL of sample.

## RESULTS AND DISCUSSION

### FRP House

The prototype of the FRP house is shown in Figure 3. Condition of the air temperature, air humidity and water content of the media inside the FRP house during mushroom cultivation are monitored automatically. The variation of air temperature around 29-39°C is relatively stable, while condition at day, night and rainy, resulted in high fluctuated of air humidity 40-98% with the water content of the media around 39-99%.

The devices inside the mushroom's FRP house consists of circuits, input blocks and output blocks which are joint by the Nodemcu microcomputer to control the air condition inside mushroom's FRP house. The input block is a soil moisture sensor and BME280 as a temperature, humidity and barometric detector. The sensor will generate an input value for the Nodemcu microcomputer, this value will be processed by Nodemcu which produces an output value to the connected devices. While the output block is a receiver a value generates by sensor through Nodemcu, such as a heater will operate if the temperature inside the mushroom's FRP house is low and the mist-maker will turn off if the humidity inside the mushroom's FRP house

is sufficient. Nodemcu has a Wi-Fi module that is able to save the values and data in the database, this can make it easier to use a smartphone to access mushroom's FRP house condition even the values or data remotely. The IoT control system is setup for operating the hot air exhaust with the mist sprayer process taking place in parallel if the air temperature at above 39°C with humidity below 60%. And when the opposite condition occurred (below 29°C), thus the water heater will actively operate spraying hot air vapor into the FRP House. This methods of IoT control mechanism will reduce the human intervention so that the growth process of mycelium and pinhead of fungal embryos can achieve optimally.

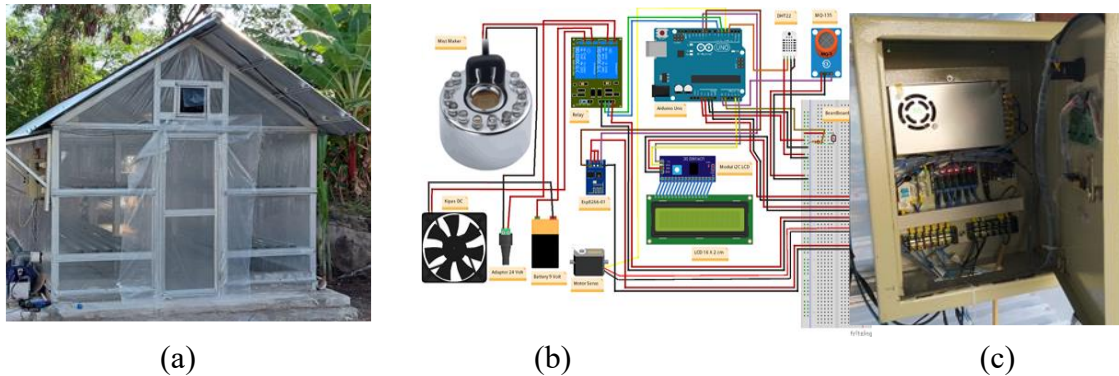

Figure 3. The prototype of the FRP house (a) with IoT circuit (b) and panel control box (c)

The generated measuring instrument and sensors performance corresponded the proposed elapsed time through the interface to display's monitor. In table 2 showed the comparison of sensor values with measuring instruments. Digital measuring instrument used to compare sensor values such as Hygrometer, lux meter and the average temperature difference of 0.92 °C and humidity of 2.1%.

Table 2. Temperature and humidity sensor testing

Temperature			Humidity		
Sensor	Device	Diff	Sensor	Device	Diff
31.7	30.8	0.9	77	76	1
31.6	30.7	0.9	78.3	77	1.3
31.7	30.7	1	78.9	78	0.9
31.8	30.7	1.1	78.3	78	0.3
31.8	30.7	1.1	79.1	79	0.1
31.8	31.3	0.5	80.2	79	1.2
32.2	31.1	1.1	83.4	82	1.4
32.2	31.2	1	82	82	0
32.1	31.5	0.6	81.3	81	0.3
32.1	31.1	1	81.2	81	0.2

Table 3 is a comparison graph of sensor values with measuring instruments. Digital measuring tools used to compare sensor values such as mini-Hygrometer, lux meter and carbon detector. The test was carried out by taking samples 30 times by getting an average temperature difference of 0.91°C, humidity 0.89%. Furthermore, the light sensor gets an average difference

of 19.76% and gas content of 10.13 ppm. The second test evaluates the performance of the tool and obtains an accuracy rate of success of 93.3%.

Table 3. Light sensor and CO<sub>2</sub> content

light			Gas Content		
Sensor	Device	Diff	Sensor	Device	Diff
192	175	17	21	10	11
187	144	43	33	12	21
182	152	30	16	9	7
103	100	3	24	16	8
170	145	25	22	20	2
-	-	-	-	-	-
-	-	-	-	-	-
144	124	20	18	7	11
169	123	46	10	3	7
118	115	3	15	8	7
124	121	3	24	16	8
128	122	6	30	20	10

### Effect of FRP House to Mushroom quality

Air conditions and lighting inside mushroom's FRP house day and night during the mushroom growth (Figure 4) contribute for the effect to the quality of harvested fresh mushroom. The results of quality analysis indicated that the range of phenotype length of 2.5-10 cm, diameter of 3-10 cm and weight 10-120 gram (Figure 5), in general the mushrooms growth from organic media are longer and heavier than non-organic growth media with more uniform dimensions except for the diameter of phenotype.

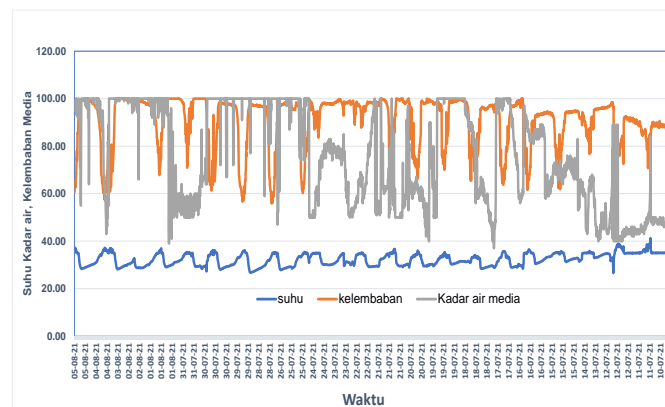

Figure 4. Fluctuation of air temperature, RH, and moisture content inside FRP House

Figure 4. is to show the effect of air condition mentioned by sensors to the growth of the mushroom



Figure 5. Dimension of harvested oyster mushroom

The hardness test and the moisture content of the mushrooms were carried out by comparing the mushrooms at the farm level as shown in Table 4, indicating that the mushrooms in the FRP house were harder and less water content than that ones at the farmer mushroom's housing at the farm level.

Table 4. Characteristics of straw mushroom

No	Parameter	average
1.	texture	865,0±100,0
2	Dimension	
	- Length (mm)	41,5±6,0
	- Width (mm)	60,0±4,0
	- Height (mm)	29,5±9,0

### Micro Laboratory Analysis

The results of micro-laboratory analysis (Table 5) showed that the fresh harvested mushroom are negative from total fungus and salmonella

Tabel 5. Analysis result of total fungus and salmonella

Code	Phase of fungus	Total fungus (cfu/g)	Salmonella (negative/25g)
A	Non organic mushroom, Bloom	2.9x10 <sup>5</sup>	negative
B	Non organic mushroom, fresh	1.0x10 <sup>5</sup>	negative
C	Organic mushroom, bloom	3.5x10 <sup>4</sup>	negative
D	Organic mushroom, fresh	6.5x10 <sup>4</sup>	negative
E	non organic mushroom, bloom	1.7x10 <sup>6</sup>	negative
F	non organic, mushroom, fresh	5.4x10 <sup>4</sup>	negative

### Active Compound Ergothioneine

The results of the analysis on functional compounds of EGT in oyster mushrooms using the HPLC method, a graphic recording of the results of HPLC analysis of dried mushrooms

with standard ethanol solvent. The average recording results from the EGT chromatography results were 0.674 mg/g as shown in Table 6

Table 6. Results of chromatogram graphic data processing from mushroom extract

Code	Area	Intercept	Slope	V (ml)	fp	B.s (g)	C (ppm)	C (%)	mg/g DW
Organic, et 70%	2,005	0,1501	0,0643	20	250	0,2006	719032,64	71,90	0,799
	2,0309	0,1501	0,0643	20	250	0,2006	729072,50	72,91	0,810
Non organic, et 70%	2,2289	0,1501	0,0643	20	250	0,2688	601370,99	60,14	0,668
	2,2626	0,1501	0,0643	20	250	0,2688	611119,98	61,11	0,679
Ethanol 96%	2,2255	0,1501	0,0643	20	250	0,2034	793432,33	79,34	0,882
	2,0676	0,1501	0,0643	20	250	0,2034	733066,64	73,31	0,815
Powder, organic	1,3702	0,1501	0,0643	20	250	0,2022	469216,53	46,92	0,521
	1,3862	0,1501	0,0643	20	250	0,2022	475369,69	47,54	0,528
Powder, anorganic	1,3431	0,1501	0,0643	20	250	0,2009	461763,43	46,18	0,513
	1,2709	0,1501	0,0643	20	250	0,2009	433817,65	43,38	0,482

The extraction process breaks down the bonds among the molecules of the material so that EGT and phenol compounds are produced with varying concentrations depending on the type of solvent used (Table 7). The results of the standard solution analysis showed that the EGT compound had a retention time of  $3.33 \pm 0.06$  minutes, while the mushroom sample showed a retention time of 3.28 to 3.30 minutes.

Table 7. Recapitulation of EGT characterization data from edible mushrooms

Solvent	Concentration EGT (mg/g DW)	Total Phenol (mg/g DW)
Ethanol 96%	$0,805 \pm 0.01$	$0,015 \pm 0.00$
Ethanol 70%	$0,848 \pm 0.05$	$0,025 \pm 0.00$

The extraction process using 70% ethanol produced higher concentrations of EGT and phenol than the extraction process using 96% ethanol. This shows that 70% of ethanol solvent is more effective used to bind EGT and phenol compounds in oyster mushrooms than that in pure solvents. This result is in line with the previous study conducted by Nguyen et al. (2012). The process of extracting the *Flammulina velutipes* mushroom using 70% ethanol was able to produce EGT and phenol compounds with higher concentrations than that the extraction using 50% and 100% of ethanol, with values of  $2.05 \pm 0.18$  mg/g and  $3.65 \pm 0,08$  DW, consecutively.

The extraction process that has been carried out can break down the bonds between the molecules of the material so that EGT and phenol compounds are produced with varying concentrations depending on the type of solvent used (Table 8). The results of the standard



solution analysis showed that the EGT compound had a retention time of  $3.33 \pm 0.06$  minutes, while the straw mushroom sample showed a retention time of 3.28 to 3.30 minutes.

Table 8. Methods and varying concentrations type of solvent for EGT

Species of mushroom	Methods	Concentration Ergothioneine (mg/g BK)
<i>Flammulina velutipes</i> Ref.: Nguyen et al. (2012)	Water	$1.50 \pm 0.21$
	Ethanol 70%	$2.05 \pm 0.18$
	Methanol 70%	$1.86 \pm 0.04$
	Acetone 70%	$1.92 \pm 0.07$
<i>Pleurotus eryngii</i>	Hot water Ref.: Yen et al. (2018)	0.86
<i>Pleurotus citrinopileatus</i>		3.73
<b>Oyster Mushroom</b>	<b>Ethanol 70%</b>	<b><math>0.67 \pm 0.01</math></b>

The extraction process for active compounds (Table 9), such as EGT and phenol, is influenced by several factors, such as solvent polarity and process conditions. A mixture of solutions has the ability to bind the active compound better than the pure solvent. This is due to the mixing of nonpolar solvents with water which can increase the polarity index of the solvent so that the extraction efficiency increases.

In addition, the increase in extraction temperature was positively correlated to the increase in antioxidant activity and polyphenols (flavonoids and total phenol), while the increase in extraction time was not positively correlated to the increase in antioxidant activity and polyphenols. In addition, the presence of agitation during the extraction process also contributes to increasing the extraction yield. This happens because the agitation process can increase the rate of diffusion and minimize the barriers to mass transfer from the solid surface into the solution (Muhamad et al., 2014).

Table 9. Results of chromatograph analysis of mushroom samples

Code	Area	V (ml)	fp	B.s (g)	C (ppm)	C (%)
Organic	2,005	20	250	0,20	719032,6	71,90
Non organic	2,2289	20	250	0,27	601371,0	60,14
Ethanol 96%	2,2255	20	250	0,20	793432,3	79,34
Powder (organic)	1,3702	20	250	0,20	469216,5	46,92
Powder (unorganic)	1,3431	20	250	0,20	461763,4	46,18

Table 10 showed that the role in synthesizing EGT is the methyltransferase enzyme which is encoded by the EGT gene and specifically remodels histidine into EGT compounds (Stampfli et al., 2020). The results of another study stated that the biosynthesis of EGT is a complex synthesis process involving various types of amino acids and carbon sources. However, in principle there are three types of amino acids that play an important role in EGT biosynthesis, namely methionine, histidine, and cysteine. Histidine acts as a starting material that plays a role in the whole series of EGT biosynthesis. Cysteine serves to provide a source of sulfur atoms, while methionine which contains the protein S-adenosyl-l-methionine (SAM) acts as a

precursor in reactions involving methyl groups. In supporting its growth, cells can use dextrose, fructose, glycerol, maltose, and sucrose as carbon sources. A suitable carbon source for EGT biosynthesis is glycerol because it is able to maintain cells in a longer stationary growth phase. In the glycolysis cycle, glycerol is broken down into glycerol-3 phosphate by the enzyme glycerol kinase. Furthermore, glycerol-3 phosphate is broken down by the enzyme glyceraldehyde-3 phosphate dehydrogenase to glycero-P which is then overhauled by triosephosphate isomerase to glyceraldehyde 3 phosphate (GAP). GAP acts as a precursor in the glycolysis process to produce pyruvic acid which will also be a substrate in the Krebs cycle. Consumption of large amounts of pyruvic acid can stimulate enzymatic reactions of amino acids to produce EGT (Yu et al., 2020).

Table 10. Concentration of ergothioneine in different species of mushroom.

Mushroom Species	Ergothioneine Content*	Mushroom Species	Ergothioneine Content*
<i>Fomitopsis pinicola</i>	0.07 ± 0.01	<i>Polyzellus multiplex</i>	0.51 ± 0.01
<i>Ganoderma applanatum</i>	0.06 ± 0.02	<i>Ramaria botrytis</i>	0.29 ± 0.03
<i>G. lucidum</i>	0.08 ± 0.02	<i>S. granulata</i>	0.09 ± 0.03
<i>G. neo-japonicum</i>	0.07 ± 0.00	<i>Lampteromyces japonicus</i>	0.43 ± 0.16

\*mg/g dw; Mean ± SD.

Sources: [Lee et al., 2009](#), [Ito et al., 2011](#).

## CONCLUSION

The research results showed that the cultivation of oyster mushroom in an FRP house with ceramic floors and plastic walls and an IoT management. The temperature of the air inside was between 29 and 35 degrees Celsius, and the relative humidity was between 60% and 90%. The weight of fresh oyster mushroom was 865 mg. The average length, width, and height of the fresh mushroom were 41.5 mm, 60.0 mm, and 29.5 mm, respectively. The microbiological test confirmed that there was no salmonella infection in the collected mushrooms. The stage of mushrooms have less total fungus than the bloom-stage mushrooms. The extraction standard method employs an EGT content of 0.674 mg/g as determined by chromatography data analysis. The oyster mushrooms can be consumed as a healthy meal, and the study of EGT showed also very prospective as one of immunotherapeutic food.

## REFERENCES

- Adiandri, R.S., Hidayah, N., dan Nugraha, S. 2018. Identification of amino acid, fatty acid, mineral content and respiration rate of straw mushroom in different stage of maturity. Proceeding the international seminar on tropical horticulture, 239-248
- Borodina, I., Kenny, L.C., McCarthy, C.M., Paramasivan, K., Pretorius, E., Roberts, T.J., van der Hoek, S.A. and Kell, D.B., 2020. The biology of ergothioneine, an antioxidant nutraceutical. *Nutrition Research Reviews*, 33(2), 190-217.
- Cheah, I.K., dan Halliwell, B. 2020. Could ergothioneine aid in the treatment of coronavirus patients? *Antioxidants*, 9, 595

- Dhalsamant, K., Dash, S.K., Bal, L.M., dan Panda, M.K. 2015. Effect of perforation mediated MAP on shelf life of mushroom (*Volvariella volvacea*). *Scientia Horticulturae*, 189, 41-50
- Dubost, N.J., Beelman, R.B., Peterson, D. and Royse, D.J., 2006. Identification and quantification of ergothioneine in cultivated mushrooms by liquid chromatography-mass spectroscopy. *International Journal of Medicinal Mushrooms*, 8(3).
- Halliwell, B., Cheah, I.K., dan Tang, R.M.Y. 2018. Ergothioneine – a diet-derived antioxidant with therapeutic potential. *FEBS Letters*, 592, 3357-3366
- Huang, X. and Nie, S., 2015. The structure of mushroom polysaccharides and their beneficial role in health. *Food & function*, 6(10), 3205-3217.
- Ito, T., Kato, M., Tsuchida, H., Harada, E., Niwa, T. and Osawa, T., 2011. Ergothioneine as an anti-oxidative/anti-inflammatory component in several edible mushrooms. *Food science and technology research*, 17(2), 103-110.
- Jamjumroon, S., Wongs-Aree, C., McGlasson, W.B., dan Sriloang, V. 2012. Extending the shelf-life of straw mushroom with high carbon dioxide treatment. *Journal of Food Agriculture and Environment*, 10(1):78-84
- Kalaras, M.D., Beelman, R.B., Holick, M.F. and Elias, R.J., 2012. Generation of potentially bioactive ergosterol-derived products following pulsed ultraviolet light exposure of mushrooms (*Agaricus bisporus*). *Food chemistry*, 135(2), 396-401.
- Kalaras, M.D., Richi, J.P., Calcagnotto, A., dan Beelman, R.B. 2017. Mushrooms: a rich source of the antioxidants ergothioneine and glutathione. *Food Chemistry*, 233, 429-433
- Kopinski, L., dan Kwiatkowska-Marks, S. 2012. Utilization of waste newspaper using oyster mushroom mycelium. *Industrial & Engineering Chemistry Research*, 51, 4440-4444
- Lee, S.H., Hwang, H.S. and Yun, J.W., 2009. Antitumor activity of water extract of a mushroom, *Inonotus obliquus*, against HT-29 human colon cancer cells. *Phytotherapy Research*, 23(12), 1784-1789.
- Nguyen, T.H., Nagasaka, R., dan Ohshima, T. 2012. Effects of extraction solvents, cooking procedures and storage conditions on the contents of ergothioneine and phenolic compounds and antioxidative capacity of cultivated mushrooms *Flammulina velutipes*. *International Journal of Food Science & Technology*, doi: 10.1111/j.1365-2621.2012.02959.x
- Nur Sakinah, M.J., Misran, A., Mahmud, T.M.M., Abdullah, S., dan Azhar, M. 2020. Evaluation of storage temperature, packing system and storage duration on postharvest quality of straw mushroom (*Volvariella volvacea*). *Food Research*, 4(3), 679-689
- Pahila, J., Ishikawa, Y., dan Ohshima, T. 2019. Effects of ergothioneine-rich mushroom extract on the oxidative stability of astaxanthin in liposomes. *Journal of Agricultural and Food Chemistry*, 67, 3491-3501
- Repine, J.E., dan Elkins, N.D. 2012. Effect of ergothioneine on acute lung injury and inflammation in cytokine insufflated rats. *Preventive Medicine*, 54, S79-S82
- Shinozaki, Y., Furuichi, K., Toyama, T., Kitajima, S., Hara, A., Iwata, Y., Sakai, N., Shimizu, M., Kaneko, S., Isozumi, N., Nagamori, S., Kanai, Y., Sugiura, T., Kato, Y., dan Wada, T. 2017. Impairment of the carnitine/organic cation transporter 1-ergothioneine axis is mediated by intestinal transporter dysfunction in chronic kidney disease. *Kidney Int.*, 92(6), 1356-1369

- Song, T.Y., Lin, H.C., Chen, C.L., Wu, J.H., Liao, J.W., dan Hu, M.L. 2014. Ergothioneine and melatonin attenuate oxidative stress and protect against learning and memory deficits in C57BL/6J mice treated with D-galactose. *Free Radic Res.*, 48(9), 1049-60
- Weigand-Heller, A.J., Kris-Etherton, P.M. and Beelman, R.B., 2012. The bioavailability of ergothioneine from mushrooms (*Agaricus bisporus*) and the acute effects on antioxidant capacity and biomarkers of inflammation. *Preventive Medicine*, 54, S75-S78.
- Yoshida, S., Shime, H., Matsumoto, M., Kasahara, M., dan Seya, T. 2019. Anti-oxidative amino acid L-ergothioneine modulates the tumor microenvironment to facilitate adjuvant vaccine immunotherapy. *Front Immunol.*,10, 671

## 1b.7. Under Process Review



### SUBMISSION

Authors Helmi Haris, Ridwan Rachmat, Tiana Fitrilia, Ahmad Syarbain  
Amar Ma'ruf, Dede Djuanda, Dian Histifarina, Bagem Sembiri  
Title Exploration of Oyster Mushrooms for Functional Fresh Food  
Section Articles  
Editor Agus Haryanto

### PEER REVIEW

#### ROUND 1

Review Version 7244-22572-2-RV.DOCX 2023-05-27  
Initiated 2023-07-04  
Last modified 2023-07-18  
Uploaded file Reviewer C 7244-23828-1-RV.DOCX 2023-07-18  
Reviewer B 7244-23460-1-RV.DOCX 2023-07-05

### EDITOR DECISION

Decision Resubmit for Review 2023-07-18  
Notify Editor Editor/Author Email Record 2023-07-18  
Editor Version 7244-22607-1-ED.DOCX 2023-05-27  
Author Version 7244-24134-1-ED.DOCX 2023-07-31 DELETE  
Upload Author Version  Tidak ada file yang dipilih

00547880 JTEP Stats



This work is licensed under a Creative Commons Attribution-ShareAlike 4.0 International License.

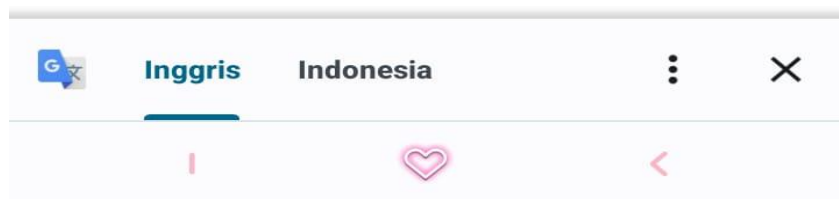

## 1b.8. Accepted Letter-Helmi Harris



# Jurnal TEKNIK PERTANIAN LAMPUNG

Jurusan Teknik Pertanian, Fakultas Pertanian, Universitas Lampung  
Jl. Sumantri Brojonegoro No. 1 Bandar Lampung 35145 Telepon (62-721) 701609 ext. 846  
<http://jurnal.fp.unila.ac.id/index.php/JTP/> email: [jurnal.tep@fp.unila.ac.id](mailto:jurnal.tep@fp.unila.ac.id)

Bandar Lampung, August 25<sup>th</sup>, 2023

Number : 91/J.TEP-L/VIII/2023  
Subject : Accepted Paper

To :

**Helmi Haris**  
University of Djuanda, Bogor

Thank you for revising the manuscript: **Physicochemical Quality of Oyster Mushroom for Functional Food** (ID 7244). We have carefully checked the revised version and we are pleased to inform you that your manuscript is **ACCEPTED** for publication in JTEP Lampung. The manuscript is being handled for further process and is scheduled for publication in **Volume 12 No.4, December 2023**.

Please visit <http://jurnal.fp.unila.ac.id/index.php/JTP/> to access the progress of your manuscript.

We are proud to share with you that JTEP is accredited as SINTA 2. Furthermore, starting Volume 11 (2022) JTEP publishes papers in English.

The APC (Article Processing Charge) fee is IDR 750,000 (seven hundred and fifty thousand rupiah). This fee should be paid through a BNI account, No. 0698202763 a/n Elhamida Rezkia Amien no later than 1 week.

Thank you for considering JTEP Lampung as the venue of your publication.

Chief Editor, JTEP Lampung,

**Prof. Dr. Ir. Agus Haryanto, M.P**

## 1b.9. CE 7244-20230731-WA0033

### Physicochemical Quality of Oyster Mushroom for Functional Food

Helmi Haris<sup>1</sup>, Ridwan Rachmat<sup>2</sup>, Tiana Fitrilia<sup>1</sup>, Ahmad Syarbaini<sup>1</sup>, Amar Ma'ruf<sup>1</sup>, Dede Djuanda<sup>1</sup>, Dian Histifarina<sup>2</sup>, and Bagem Sembiring<sup>3</sup>

<sup>1</sup>University of Djuanda. Jl. Raya Ciawi Bogor, West Java. Indonesia

<sup>2</sup>Research Center for Appropriate Technology, National Research and Innovation Agency. Jl. K.S. Tubun No 5, Subang, West Java, Indonesia

#### ABSTRACT

*This article presents studies on the physicochemical quality of oyster mushrooms grown within a housing and controlled by the Internet of Things (IoT). The goals of this study were to assess (1) the impact of indoor air quality on the growth and quality of mushrooms and (2) the antioxidant content of oyster mushrooms. In this study, the air temperature and humidity of oyster mushroom house per unit time was recorded and controlled automatically by an IoT system. Additionally, their physicochemical and microbiological quality were evaluated using physico-analytical instruments, and the potency of their ergothioneine (EGT) content was investigated using the HPLC method. The temperature of the air inside was between 29 and 35 °C, and the relative humidity was between 60% and 90%. The average texture of mushroom is soft. The average length, width, and height of the fresh mushroom were 41.5 mm, 60.0 mm, and 29.5 mm, respectively. The microbiological test confirmed that there was no salmonella infection in the collected mushrooms. The button-stage mushrooms have less total fungus than the bloom-stage mushrooms. The extraction standard method employs an EGT content of 0.674 mg/g as determined by chromatography data analysis. The oyster mushrooms can be consumed as a healthy meal, and the study of EGT showed also very prospective as one of immunotherapeutic food.*

*Keywords: ergothioneine, Fibre-reinforced plastic house, Internet of think, oyster mushrooms*

#### 1. INTRODUCTION

The oyster mushroom is a type of mushroom that specifically grows in tropical countries such as Indonesia. Oyster mushrooms are grown on aggregate media one of them is the paddy waste from the paddy cultivation. Therefore, generally at the rice production centre area mostly becoming the centre for mushrooms production. This can be correlated with the availability of biomass as the main growing media for mushroom.

Cultivating high quality of the mushrooms required high-quality seeds, the high-quality media resources as well as the optimal environment due to the mushrooms are sensitive to climate change. To fulfil the optimum condition for mushrooms cultivation, an adequate production house is required to be implemented by environment controller and high-quality safety materials for growing media and to avoid using industrial in order to produce free contaminant (Kopinski & Kwiatkowska-Marks, 2012).

A prototype of Fiber Reinforced Plastic (FRP) house (Rachmat & Horibe, 1999) is a proper construction for mushroom production housing, and it is implemented with an Internet of things (IoT)

Commented [NN1]: Belum ada di Daftar Pustaka. Harap ditambahkan

based connected to various devices microcontroller. The mushroom production house used IoT control system to make it easier to monitor the air condition inside the house online by mean of displaying the value generated from the installed sensors inside the house. According to [Asyarita & Lestari \(20xx\)](#), temperature and humidity in production house of mushrooms greatly affect the growth process of mushrooms. So that the mushrooms do not rot, brown and wilt, the humidity in the mushroom production house should not be too high or low, ranging from 75%-90% at the humidity level of the mushroom production house.

**Commented [NN2]:** Belum ada di Daftar Pustaka. Harap ditambahkan

Research by [Dhiya et al. \[5\]](#) who conducted an analysis of the efficiency of the edible mushroom stated that the growth of high consumption of mushrooms was due to the high protein content of edible mushrooms. The mushroom has good properties for the nutritional needs of the human body such as being rich in protein, vitamin C and various water-soluble vitamins (riboflavin, biotin and thiamine), fat (5.7%), carbohydrates (56,8%), amino acids, unsaturated fats, essential minerals (sodium, potassium and phosphorus) and has a low calorific value [\[6\]](#).

**Commented [NN3]:** Belum ada di Daftar Pustaka. Harap ditambahkan

Mushrooms contain various types of nutrients those are beneficial to the health of the human body, such as carbohydrates, proteins, and fats. Several types of essential nutrients found in edible mushrooms include amino acids (glutamic acid, proline, phenylalanine, lysine, histidine, etc.), fatty acids (lauric, palmitic, oleic, lenoleic, etc.), potassium, calcium, and phosphorus ([Adiandri et al., 2018](#)). One type of essential amino acid found in mushrooms is ergothioneine (EGT). EGT is a derivative of histidine which contains functional groups of sulfur atoms and hydrogen atoms (-SH) and it can only be synthesized by fungi and actinobacteria ([Borodina et al., 2020](#); [Halliwell et al., 2018](#)).

**Commented [NN4]:** Belum ada di Daftar Pustaka. Harap ditambahkan

Mushrooms as a food source have been reported to have the highest level of ergothioneine compared to any other food source ([Dubost et al., 2006](#); [Dubost et al., 2007](#)). In an early report, it has been shown that if we consume mushrooms as our regular food, the bioavailability of ergothioneine remains in our body ([Weigand-Heller et al., 2012](#)). The ergothioneine chemical compound is accumulated in the fruiting bodies as well as in the mycelia of the mushroom ([Borodina et al., 2019](#); [Kalaras et al., 2020](#)). Several studies have been conducted with samples of mushrooms to describe improved ergothioneine production by the addition of several additives, such as aspartic acid, lysine, and methionine, which demonstrate increased ergothioneine biosynthesis ([Lee et al., 2009](#)). In addition, it has also been described that the production of ergothioneine increases with increased pH and is higher under alkaline conditions ([Huang & Nie, 2015](#)).

**Commented [NN5]:** Belum ada di Daftar Pustaka. Harap ditambahkan

Research on the identification and isolation of EGT from several fungal varieties has been carried out. The content of EGT in mushrooms is quite high and has good antioxidant activity. In addition, differences in genus and species of fungi have different chemical compositions contained in them so that it affects the proportion of EGT in mushrooms ([Kalaras et al., 2017](#)). The results of the literature study indicate that the identification and isolation of EGT from edible mushroom has never been done. Therefore, research to explore the opportunity to use edible mushroom as a source of EGT needs to be done.

**Commented [NN6]:** 2019 atau 2020? Mohon klarifikasi  
Jika Referensi ini benar 2019, mohon ditambahkan ke Daftar Pustaka

The provision of production house that meets food safety requirements is absolutely necessary to produce safe oyster mushrooms for consumption. Meanwhile the technology development of this mushroom production that meets food safety standards for the isolation of ergothioneine as an antioxidant is a potential matter in exploration of mushroom is still limited. This paper describes the research results of the prototype of FRP house with the air condition variation inside the house and the effect of air condition against mushroom quality. The effect of the IoT implementation in



controlling the air condition system as well as minimizing the human contact during oyster mushroom growing during cultivation periods, and to explore the value added of mushroom through the ergothioneine (EGT) analysis as the of antioxidant content in mushroom. The scope of research includes (1) constructing a prototype of FRP house with IoT control system for oyster mushroom cultivation; (2) to evaluate the air condition variation inside the house and the effect of air condition against mushroom growth and quality; (3) Analysis of antioxidant content in mushroom.

## 2. MATERIAL AND METHODS

The research was conducted in 2022 at the field laboratory of Post Harvest Research Center of IAARD and analytical laboratory of University of Djuanda. The materials used in this research are analytical grade chemicals. The effectiveness of antioxidant properties on isolated EGT was measured by in vitro method. The main material and controlled apparatus respectively for (1) the construction material for building a prototype of FRP house with IoT control system for oyster mushroom cultivation; (2) The atmospheric air meter apparatus for investigating the air condition variation inside the house and the effect of air condition against mushroom growth and quality; (3) Analysis of antioxidant content in mushroom by HPLC method. The materials used in this research are analytical grade chemicals. The effectiveness of antioxidant properties on isolated EGT was measured by in vitro method.

### 2.1. FRP House

The Fibre Reinforced Plastic (FRP) house constructed (Figure 1) at an area of 650 cm x 350 cm with a light steel alloy frames and the roof is covered by a thin metal sheet roof and all each the wall blanketed by fibre reinforced plastic. (FRP), and white ceramic tile's floor. There are two shelves at inside the FRP house with of 400 cm length and 100 cm width respectively.

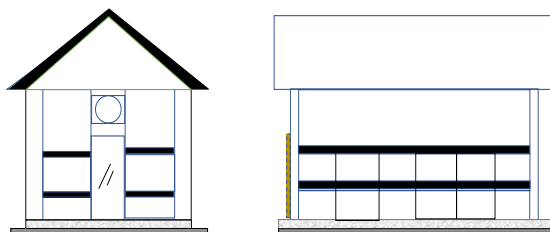

Figure 1. Prototype of FRP house model of straw mushroom (dimentions 3.0 m x 5.0 m x 3.0 m)

The FRP House implemented with an Internet of Think (IoT) system (Figure 2) to actuate a set of devices to measure the parameters of air temperature, air humidity, moisture content of the media. The control devices are 30 nozzles of mist sprayer setup along the rack of shelves above the media which are connected with a special hose. Hot air temperatures above 35 °C, caused the exhaust fan is on, whenever a drastic drop of air temperature inside the FRP house below 29 °C, thus the heater will operate automatically to increase the room temperature. The controller specification showed in Table 1 are set at day and night time with the elapsed time of intervals are enable to monitor the parameters conditions to avoid disturbance during mushrooms growth.

The Arduino Node MCU is an open-source platform based on IoT, which is able to implement various commands with programming languages. The application of the C programming language uses a sketch on the Arduino IDE (Integrated Development Environment), which is capable of programming various kinds of microcontrollers including Node MCU. The Node MCU has a small size compared to Arduino UNO, by using the ESP8266 module, there are GPIO (General-purpose input/output), PWM (Pulse Width Modulation), I2C, UART (Universal Asynchronous Receiver Transmitter), 1-Wire and ADC (Analog to Digital Converter).

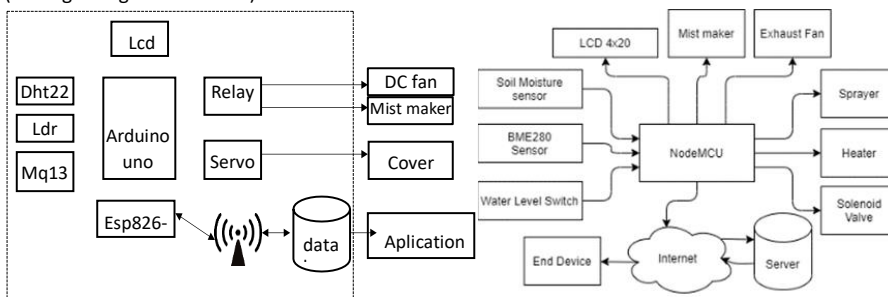

Figure 2. Architecture of IoT of production house in oyster mushroom

Tabel 1. Component and specification of control system

Component	Specifications
Sensor BME280	Air temperature and humidity sensor
Soil Moisture sensor	Soil moisture content controller
Water Level sensor	Water height controller
Mist-maker	Fog production and controller
Exhaust fan	Air humidity controller
Arduino IDE 1.8.9, fritzing	Temperature and humidity

Commented [NN7]: Semua Tabel dan Gambar harus disebut di dalam teks. Mohon ditambahkan

## 2.2. Cultivation Process Procedure

Mushroom cultivation process procedure was carried out inside FRP House and utilized the organic components which are mixed and fermentation process for 4 days to be a compost, and then fill into bag log evenly in a plastic sacks assembled inside FRP House. The layers of compost were pasteurized inside FRP house with closed cover condition tightly and then fogging with hot air at temperature 60 to 65 °C for 8 hours. The mushroom seeds were inside over the bag logs of compost and then to be incubated for 3 days at around 29-30 °C of inside air temperature. The treatment during mushroom growth up to harvest periods comprised of the inside air temperature, humidity and soil water content. The treatment during mushroom growth up to harvest periods comprised of the inside air temperature, humidity by thermos-hygrograph and soil water content sensor at every 20 min. The first harvesting conducted two weeks after seedling where the growth mushroom head is indicated by totally white head blooming.

## 2.3. Extraction of the Active Compound Ergothioneine

Ergothioneine is a complex compound of antioxidant. The isolation of ergothioneine EGT compounds from the harvested fresh mushrooms was carried out by the extraction method refers to the method

developed by [Ito et al. \(2011\)](#) and [Nguyen et al. \(2012\)](#) with some modifications. Pre-treatment (blanching and non-blanching), mushroom before drying methods by electric oven drying.

The experimental factors of extraction employed the temperature 40°C and 60°C respectively with the variation of the extraction solvent (water and ethanol 30% (v/v), 50% (v/v), 70% ethanol (v/v), and ethanol 100% (v/v)). The extraction procedure utilized 10 grams of dry mushroom powder and 200 mL of solvent which has been heated in a shaking water bath according to variations in temperature. The solvent along with the solute was continuously agitated at 100 rpm for 1 hour, then cooled at room temperature for 2 hours. Then it was centrifuged at 600 rpm for 15 minutes at 25°C. The achieved of the process is supernatant which was transferred to a conical tube for further evaporation using a vacuum evaporator at a temperature of 40°C to evaporate the remaining solvent up to be a paste of EGT extract. Furthermore, the paste of EGT was dried by the freeze-drying method. The dried EGT sample was then weighed to measure as the extraction yield.

#### 2.4. EGT concentration analysis

Analysis of the concentration of EGT in the oyster mushroom extract used the HPLC method referring to the method used by [Kalaras et al. \(2017\)](#) with some modifications. The mushroom powder (0.5 g) and 7 ml of **ethanol** was put into a 15 ml centrifuge tube (consisting of 10 mM dithiothreitol, 100 M betaine, 100 M 2-mercapto-1-methyl imidazole) and 3 ml of distilled water was added and homogenized with a vortex for 10 seconds. A total of 2 mL of 1% SDS solution dissolved in ethanol was added and homogenized with a vortex for 10 seconds. Then the suspension was centrifuged for 20 minutes at 4000 rpm and 25°C. The supernatant formed was transferred to a 15 mL centrifugation tube. Then, 1 mL of the supernatant was put into a micro tube and allowed to stand for 24 hours. The solid formed from this process is then dissolved into 0.5 mL of aqua bides and homogenized using a vortex until it dissolves completely. Samples that have been stored in micro-tubes were centrifuged at 10,000 rpm for 1 minute. The supernatant formed was then filtered using a syringe filter (0.45 100 m) and put into a glass vial for HPLC analysis.

HPLC analysis was performed using column C18. The volume of the solution injected was 10 µL. The mobile phases used mobile phase A (3% acetonitrile, 0.1% TEA, 50 mM dibasic sodium phosphate dissolved in distilled water), mobile phase B (acetonitrile), and mobile phase C (water). The separation was performed on the elution gradient as follows: 0 minutes 15:85 (B:C), 0-5 minutes set at a slope of 5:15:85 (A:B:C), 5-6 minutes set at a slope of 10:90 ( B:C), 6-8 minutes at 3:97 (B:C), and 8-15 at 3:97 (B:C). EGT was detected at a wavelength of 254 nm with a peak retention time of 5.7 min which was quantified using an external standard curve.

The antioxidant activity of EGT from edible mushroom was carried out by measuring the radical scavenging activity of DPPH referring to the method of [Pahila et al. \(2019\)](#). The analytical procedure comprised of 50 L of straw mushroom extract is added to 50 L of DPPH solution (100 M in 85% ethanol) and stirred using a vortex. After 15 minutes, the solution mixture was put into a 50 L Pyrex NMR capillary tube, then the DPPH radical spin resonance was measured with a spectrometer at a wavelength of 517. The spectrometer settings as microwave power, 1.2 mW; microwave frequency 9149.3 MHz; field magnet, 325.5 25 mT; and the sweep time, 30 seconds. Various concentrations of EGT were measured for resonance to construct a standard curve. The radical scavenging activity of DPPH was expressed as mmol equivalent of EGT per mL of sample.

### 3. RESULTS AND DISCUSSION

#### 3.1. FRP House

The prototype of the FRP house is shown in Figure 3. Condition of the air temperature, air humidity and water content of the media inside the FRP house during mushroom cultivation are monitored automatically. The variation of air temperature around 29-39°C is relatively stable, while condition at day, night and rainy, resulted in high fluctuated of air humidity 40-98% with the water content of the media around 39-99%.

The devices inside the mushroom's FRP house consists of circuits, input blocks and output blocks which are joint by the Nodemcu microcomputer to control the air condition inside mushroom's FRP house. The input block is a soil moisture sensor and BME280 as a temperature, humidity and barometric detector. The sensor will generate an input value for the Nodemcu microcomputer, this value will be processed by Nodemcu which produces an output value to the connected devices. While the output block is a receiver a value generates by sensor through Nodemcu, such as a heater will operate if the temperature inside the mushroom's FRP house is low and the mist-maker will turn off if the humidity inside the mushroom's FRP house is sufficient. Nodemcu has a Wi-Fi module that is able to save the values and data in the database, this can make it easier to use a smartphone to access mushroom's FRP house condition even the values or data remotely. The IoT control system is setup for operating the hot air exhaust with the mist sprayer process taking place in parallel if the air temperature at above 39 °C with humidity below 60%. And when the opposite condition occurred (below 29 °C), thus the water heater will actively operate spraying hot air vapor into the FRP House. This methods of IoT control mechanism will reduce the human intervention so that the growth process of mycelium and pinhead of fungal embryos can achieve optimally.

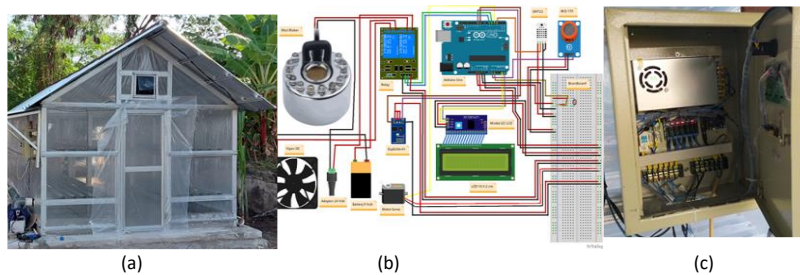

Figure 3. The prototype of the FRP house (a) with IoT circuit (b) and panel control box (c)

The generated measuring instrument and sensors performance corresponded the proposed elapsed time through the interface to display's monitor. In table 2 showed the comparison of sensor values with measuring instruments. Digital measuring instrument used to compare sensor values such as hygrometer, lux meter and the average temperature difference of 0.92 °C and humidity of 2.1%.

Table 2. Temperature and humidity sensor testing

Temperature			Humidity		
Sensor	Device	Diff	Sensor	Device	Diff
31.7	30.8	0.9	77	76	1
31.6	30.7	0.9	78.3	77	1.3
31.7	30.7	1	78.9	78	0.9
31.8	30.7	1.1	78.3	78	0.3

31.8	30.7	1.1	79.1	79	0.1
31.8	31.3	0.5	80.2	79	1.2
32.2	31.1	1.1	83.4	82	1.4
32.2	31.2	1	82	82	0
32.1	31.5	0.6	81.3	81	0.3
32.1	31.1	1	81.2	81	0.2

Table 3 is a comparison graph of sensor values with measuring instruments. Digital measuring tools used to compare sensor values such as mini-Hygrometer, lux meter and carbon detector. The test was carried out by taking samples 30 times by getting an average temperature difference of 0.91 °C, humidity 0.89%. Furthermore, the light sensor gets an average difference of 19.76% and gas content of 10.13 ppm. The second test evaluates the performance of the tool and obtains an accuracy rate of success of 93.3%.

Table 3. Light sensor and CO<sub>2</sub> content

light			Gas Content		
Sensor	Device	Diff	Sensor	Device	Diff
192	175	17	21	10	11
187	144	43	33	12	21
182	152	30	16	9	7
103	100	3	24	16	8
170	145	25	22	20	2
-	-	-	-	-	-
-	-	-	-	-	-
144	124	20	18	7	11
169	123	46	10	3	7
118	115	3	15	8	7
124	121	3	24	16	8
128	122	6	30	20	10

### 3.2. Effect of FRP House on Mushroom quality

Air conditions and lighting inside mushroom's FRP house day and night during the mushroom growth (Figure 4) contribute for the effect to the quality of harvested fresh mushroom. The results of quality analysis indicated that the range of phenotype length of 2.5-10 cm, diameter of 3-10 cm and weight 10-120 gram (Figure 5), in general the mushrooms growth from organic media are longer and heavier than non-organic growth media with more uniform dimensions except for the diameter of phenotype. Figure 4. is to show the effect of air condition mentioned by sensors to the growth of the mushroom,

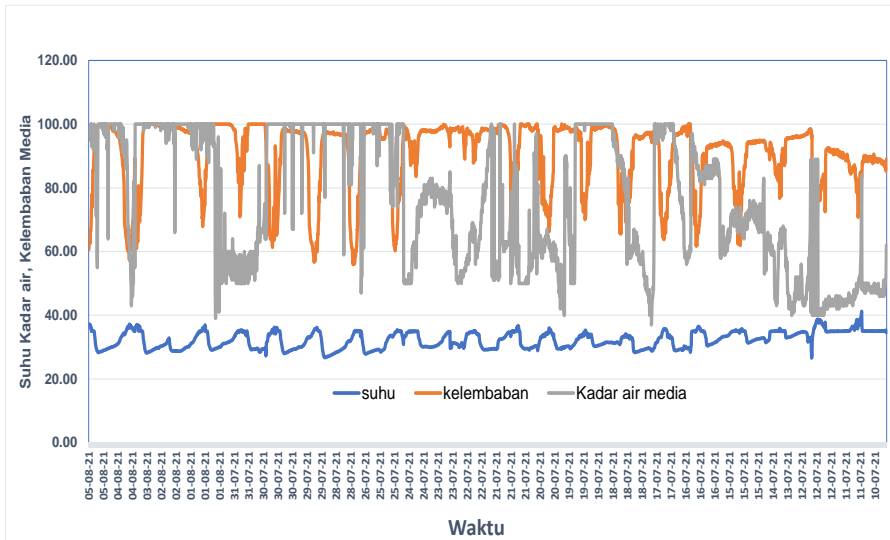

Figure 4. Fluctuation of air temperature, RH, and moisture content inside FRP House

Commented [NNS]: Semua komponen gambar agar diingkriskan: waktu, suhu, kadar air, kelembaban  
Perhatikan juga sumbu Y



Figure 5. Dimension of harvested oyster mushroom

The hardness test and the moisture content of the mushrooms were carried out by comparing the mushrooms at the farm level as shown in Table 4, indicating that the mushrooms in the FRP house were harder and less water content than that ones at the farmer mushroom's housing at the farm level.

Table 4. Characteristics of straw mushroom

No	Parameter	average
1.	texture	Soft
2.	Dimension	
	- Length (mm)	41.5±6.0
	- Width (mm)	60.0±4.0
	- Height (mm)	29.5±9.0

### 3.3. Micro Laboratory Analysis

The results of micro-laboratory analysis (Table 5) showed that the fresh harvested mushroom are negative from total fungus and salmonella

Tabel 5. Analysis result of total fungus and salmonella

Code	Phase of fungus	Total fungus (CFU/g)	<i>Salmonella</i> (negative/25g)
A	Non organic mushroom, Bloom	2.9x10 <sup>5</sup>	negative
B	Non organic mushroom, fresh	1.0x10 <sup>5</sup>	negative
C	Organic mushroom, bloom	3.5x10 <sup>4</sup>	negative
D	Organic mushroom, fresh	6.5x10 <sup>4</sup>	negative
E	non organic mushroom, bloom	1.7x10 <sup>6</sup>	negative
F	non organic, mushroom, fresh	5.4x10 <sup>4</sup>	negative

#### 3.3.1. Active Compound Ergothioneine

The results of the analysis on functional compounds of EGT in oyster mushrooms using the HPLC method, a graphic recording of the results of HPLC analysis of dried mushrooms with standard ethanol solvent. The average recording results from the EGT chromatography results were 0.674 mg/g as shown in Table 6.

Table 6. Results of chromatogram graphic data processing from mushroom extract

Code	Area	Intercept	Slope	V (ml)	fp	B.s (g)	C (ppm)	C (%)	mg/g DW
Organic, et 70%	2.005	0.1501	0.0643	20	250	0.2006	719032.64	71.90	0.799
	2.0309	0.1501	0.0643	20	250	0.2006	729072.50	72.91	0.810
Non organic, et 70%	2.2289	0.1501	0.0643	20	250	0.2688	601370.99	60.14	0.668
	2.2626	0.1501	0.0643	20	250	0.2688	611119.98	61.11	0.679
Ethanol 96%	2.2255	0.1501	0.0643	20	250	0.2034	793432.33	79.34	0.882
	2.0676	0.1501	0.0643	20	250	0.2034	733066.64	73.31	0.815
Powder, organic	1.3702	0.1501	0.0643	20	250	0.2022	469216.53	46.92	0.521
	1.3862	0.1501	0.0643	20	250	0.2022	475369.69	47.54	0.528
Powder, anorganic	1.3431	0.1501	0.0643	20	250	0.2009	461763.43	46.18	0.513
	1.2709	0.1501	0.0643	20	250	0.2009	433817.65	43.38	0.482

The extraction process breaks down the bonds among the molecules of the material so that EGT and phenol compounds are produced with varying concentrations depending on the type of solvent used (Table 7). The results of the standard solution analysis showed that the EGT compound had a retention time of 3.33 ± 0.06 minutes, while the mushroom sample showed a retention time of 3.28 to 3.30 minutes.

Table 7. Recapitulation of EGT characterization data from edible mushrooms

Solvent	Concentration EGT (mg/g DW)	Total Phenol (mg/g DW)
Ethanol 96%	0.805 ± 0.01	0.015 ± 0.00
Ethanol 70%	0.848 ± 0.05	0.025 ± 0.00

The extraction process using 70% ethanol produced higher concentrations of EGT and phenol than the extraction process using 96% ethanol. This shows that 70% of ethanol solvent is more effective used to bind EGT and phenol compounds in oyster mushrooms than that in pure solvents. This result is in line with the previous study conducted by [Nguyen et al. \(2012\)](#). The process of extracting the *Flammulina velutipes* mushroom using 70% ethanol was able to produce EGT and phenol compounds with higher concentrations than that the extraction using 50% and 100% of ethanol, with values of  $2.05 \pm 0.18$  mg/g and  $3.65 \pm 0, 08$  DW, consecutively.

The extraction process that has been carried out can break down the bonds between the molecules of the material so that EGT and phenol compounds are produced with varying concentrations depending on the type of solvent used (Table 8). The results of the standard solution analysis showed that the EGT compound had a retention time of  $3.33 \pm 0.06$  minutes, while the straw mushroom sample showed a retention time of 3.28 to 3.30 minutes.

Table 8. Methods and varying concentrations type of solvent for EGT

Mushroom species	Methods	Ergothioneine concentration (mg/g dw)
<i>Flammulina velutipes</i> ( <a href="#">Nguyen et al., 2012</a> )	Water	$1.50 \pm 0.21$
	Ethanol 70%	$2.05 \pm 0.18$
	Methanol 70%	$1.86 \pm 0.04$
	Acetone 70%	$1.92 \pm 0.07$
<i>Pleurotus eryngii</i>	Hot water ( <a href="#">Yen et al., 2018</a> )	0.86
<i>Pleurotus citrinopileatus</i>	Hot water ( <a href="#">Yen et al., 2018</a> )	3.73
<i>Oyster Mushroom</i>	Ethanol 70%	$0.67 \pm 0.01$

The extraction process for active compounds (Table 9), such as EGT and phenol, is influenced by several factors, such as solvent polarity and process conditions. A mixture of solutions has the ability to bind the active compound better than the pure solvent. This is due to the mixing of nonpolar solvents with water which can increase the polarity index of the solvent so that the extraction efficiency increases.

In addition, the increase in extraction temperature was positively correlated to the increase in antioxidant activity and polyphenols (flavonoids and total phenol), while the increase in extraction time was not positively correlated to the increase in antioxidant activity and polyphenols. In addition, the presence of agitation during the extraction process also contributes to increasing the extraction yield. This happens because the agitation process can increase the rate of diffusion and minimize the barriers to mass transfer from the solid surface into the solution ([Muhamad et al., 2014](#)).

Table 9. Results of chromatograph analysis of mushroom samples

Code	Area	V (ml)	fp	B.s (g)	C (ppm)	C (%)
Organic	2.0050	20	250	0.20	719032.6	71.90
Non organic	2.2289	20	250	0.27	601371.0	60.14
Ethanol 96%	2.2255	20	250	0.20	793432.3	79.34
Powder (organic)	1.3702	20	250	0.20	469216.5	46.92
Powder (unorganic)	1.3431	20	250	0.20	461763.4	46.18

Commented [NN9]: Belum ada di Daftar Pustaka. Harap ditambahkan



Table 10 showed that the role in synthesizing EGT is the methyltransferase enzyme which is encoded by the EGT gene and specifically remodels histidine into EGT compounds (Stampfli *et al.*, 2020). The results of another study stated that the biosynthesis of EGT is a complex synthesis process involving various types of amino acids and carbon sources. However, in principle there are three types of amino acids that play an important role in EGT biosynthesis, namely methionine, histidine, and cysteine. Histidine acts as a starting material that plays a role in the whole series of EGT biosynthesis. Cysteine serves to provide a source of sulfur atoms, while methionine which contains the protein S-adenosyl-l-methionine (SAM) acts as a precursor in reactions involving methyl groups. In supporting its growth, cells can use dextrose, fructose, glycerol, maltose, and sucrose as carbon sources. A suitable carbon source for EGT biosynthesis is glycerol because it is able to maintain cells in a longer stationary growth phase. In the glycolysis cycle, glycerol is broken down into glycerol-3 phosphate by the enzyme glycerol kinase. Furthermore, glycerol-3 phosphate is broken down by the enzyme glyceraldehyde-3 phosphate dehydrogenase to glyceron-P which is then overhauled by triosephosphate isomerase to glyceraldehyde 3 phosphate (GAP). GAP acts as a precursor in the glycolysis process to produce pyruvic acid which will also be a substrate in the Krebs cycle. Consumption of large amounts of pyruvic acid can stimulate enzymatic reactions of amino acids to produce EGT (Yu *et al.*, 2020).

Commented [NN10]: Belum ada di Daftar Pustaka. Harap ditambahkan

Commented [NN11]: Belum ada di Daftar Pustaka. Harap ditambahkan

Table 10. Concentration of ergothioneine in different mushroom species (Lee *et al.*, 2009; Ito *et al.*, 2011).

Mushroom Species	Ergothioneine Content*	Mushroom Species	Ergothioneine Content*
<i>Fomitopsis pinicola</i>	0.07 ± 0.01	<i>Polyozellus multiplex</i>	0.51 ± 0.01
<i>Ganoderma applanatum</i>	0.06 ± 0.02	<i>Ramaria botrytis</i>	0.29 ± 0.03
<i>G. lucidum</i>	0.08 ± 0.02	<i>S. granulatus</i>	0.09 ± 0.03
<i>G. neo-japonicum</i>	0.07 ± 0.00	<i>Lampteromyces japonicus</i>	0.43 ± 0.16

\*mg/g dw; Mean ± SD.

#### 4. CONCLUSION

The research results showed that the cultivation of oyster mushroom in an FRP house with ceramic floors and plastic walls and an IoT management. The temperature of the air inside was between 29 and 35 degrees Celsius, and the relative humidity was between 60% and 90%. The average texture of fresh oyster mushroom was soft. The average length, width, and height of the fresh mushroom were 41.5 mm, 60.0 mm, and 29.5 mm, respectively. The microbiological test confirmed that there was no salmonella infection in the collected mushrooms. The stage of mushrooms have less total fungus than the bloom-stage mushrooms. The extraction standard method employs an EGT content of 0.674 mg/g as determined by chromatography data analysis. The oyster mushrooms can be consumed as a healthy meal, and the study of EGT showed also very prospective as one of immunotherapeutic food.

#### REFERENCES

Adiandri, R.S., Hidayah, N., dan Nugraha, S. (2018). Identification of amino acid, fatty acid, mineral content and respiration rate of straw mushroom in different stage of maturity. *Proceeding the International Seminar on Tropical Horticulture*, 239-248.

Commented [NN12]: Jumlah References min 20 dari jurnal. Selebihnya boleh dari Buku, Report, Statistik, Standard, Thesis. Reference dg highlight kuning tidak ditemukan di dalam teks (tidak dirujuk). Jika memang digunakan agar ditempatkan dalam teks yang sesuai. Di dalam teks terdapat beberapa Rujukan yang belum ada di Daftar References (mohon ditambahkan).

- Borodina**, I., Kenny, L.C., McCarthy, C.M., Paramasivan, K., Pretorius, E., Roberts, T.J., van der Hoek, S.A., & Kell, D.B., (2020). The biology of ergothioneine, an antioxidant nutraceutical. *Nutrition Research Reviews*, 33(2), 190-217. <https://doi.org/10.1017/s0954422419000301>
- Cheah**, I.K., & Halliwell, B. 2020. Could ergothioneine aid in the treatment of coronavirus patients? *Antioxidants*, 9, 595
- Dhalsamant**, K., Dash, S.K., Bal, L.M., dan Panda, M.K. 2015. Effect of perforation mediated MAP on shelf life of mushroom (*Volvarela volvacea*). *Scientia Horticulturae*, 189, 41-50
- Dubost**, N.J., Beelman, R.B., Peterson, D., & Royse, D.J. (2006). Identification and quantification of ergothioneine in cultivated mushrooms by liquid chromatography-mass spectroscopy. *International Journal of Medicinal Mushrooms*, 8(3), 215-222. <http://dx.doi.org/10.1615/IntJMedMushr.v8.i3.30>
- Halliwell**, B., Cheah, I.K., & Tang, R.M.Y. (2018). Ergothioneine – A diet-derived antioxidant with therapeutic potential. *FEBS Letters*, 592(20), 3357-3366. <https://doi.org/10.1002/1873-3468.13123>
- Huang**, X., & Nie, S., (2015). The structure of mushroom polysaccharides and their beneficial role in health. *Food & function*, 6(10), 3205-3217. <https://doi.org/10.1039/c5fo00678c>
- Ito**, T., Kato, M., Tsuchida, H., Harada, E., Niwa, T., & Osawa, T. (2011). Ergothioneine as an anti-oxidative/anti-inflammatory component in several edible mushrooms. *Food Science and Technology Research*, 17(2), 103-110.
- Jamjumroon**, S., Wongs-Aree, C., McGlasson, W.B., dan Sriolang, V. 2012. Extending the shelf-life of straw mushroom with high carbon dioxide treatment. *Journal of Food Agriculture and Environment*, 10(1):78-84
- Kalaras**, M.D., Beelman, R.B., Holick, M.F., & Elias, R.J. (2012). Generation of potentially bioactive ergosterol-derived products following pulsed ultraviolet light exposure of mushrooms (*Agaricus bisporus*). *Food chemistry*, 135(2), 396-401. <https://doi.org/10.1016/j.foodchem.2012.04.132>
- Kalaras**, M.D., Richi, J.P., Calcagnotto, A., & Beelman, R.B. (2017). Mushrooms: A rich source of the antioxidants ergothioneine and glutathione. *Food Chemistry*, 233, 429-433. <https://doi.org/10.1016/j.foodchem.2017.04.109>
- Kopinski**, L., & Kwiatkowska-Marks, S. (2012). Utilization of waste newspaper using oyster mushroom mycelium. *Industrial & Engineering Chemistry Research*, 51(11), 4440-4444. <https://doi.org/10.1021/ie202765b>
- Lee**, S.H., Hwang, H.S., & Yun, J.W., (2009). Antitumor activity of water extract of a mushroom, *Inonotus obliquus*, against HT-29 human colon cancer cells. *Phytotherapy Research*, 23(12), 1784-1789. <https://doi.org/10.1002/ptr.2836>
- Nguyen**, T.H., Nagasaka, R., & Ohshima, T. (2012). Effects of extraction solvents, cooking procedures and storage conditions on the contents of ergothioneine and phenolic compounds and antioxidative capacity of cultivated mushrooms *Flammulina velutipes*. *International Journal of Food Science & Technology*, 47(6), 1193-1205. <https://doi.org/10.1111/j.1365-2621.2012.02959.x>
- Nur Sakinah**, M.J., Misran, A., Mahmud, T.M.M., Abdullah, S., dan Azhar, M. 2020. Evaluation of storage temperature, packing system and storage duration on postharvest quality of straw mushroom (*Volvarela volvacea*). *Food Research*, 4(3), 679-689

- Pahla**, J., Ishikawa, Y., & Ohshima, T. (2019). Effects of ergothioneine-rich mushroom extract on the oxidative stability of astaxanthin in liposomes. *Journal of Agricultural and Food Chemistry*, **67**(12), 3491-3501. <https://doi.org/10.1021/acs.jafc.9b00485>
- Repine**, J.E., dan Elkins, N.D. 2012. Effect of ergothioneine on acute lung injury and inflammation in cytokine insufflated rats. *Preventive Medicine*, **54**, S79-S82
- Shinozaki**, Y., Furuichi, K., Toyama, T., Kitajima, S., Hara, A., Iwata, Y., Sakai, N., Shimizu, M., Kaneko, S., Isozumi, N., Nagamori, S., Kanai, Y., Sugiura, T., Kato, Y., dan Wada, T. 2017. Impairment of the carnitine/organic cation transporter 1-ergothioneine axis is mediated by intestinal transporter dysfunction in chronic kidney disease. *Kidney Int.*, **92**(6), 1356-1369
- Song**, T.Y., Lin, H.C., Chen, C.L., Wu, J.H., Liao, J.W., dan Hu, M.L. 2014. Ergothioneine and melatonin attenuate oxidative stress and protect against learning and memory deficits in C57BL/6J mice treated with D-galactose. *Free Radic Res.*, **48**(9), 1049-60
- Weigand**-Heller, A.J., Kris-Etherton, P.M., & Beelman, R.B. (2012). The bioavailability of ergothioneine from mushrooms (*Agaricus bisporus*) and the acute effects on antioxidant capacity and biomarkers of inflammation. *Preventive Medicine*, **54**, S75-S78. <https://doi.org/10.1016/j.ypmed.2011.12.028>
- Yoshida**, S., Shime, H., Matsumoto, M., Kasahara, M., dan Seya, T. 2019. Anti-oxidative amino acid L-ergothioneine modulates the tumor microenvironment to facilitate adjuvant vaccine immunotherapy. *Front Immunol.*, **10**, 671



## 1b.10.a. the result of the improvements according

The screenshot displays a Gmail interface on a web browser. The address bar shows the URL: `mail.google.com/mail/u/0/#inbox/QgrcHrhxpQDgXlbpwvFPsWBjrmRHtWmL`. The Gmail header includes a search bar with the text "Search in mail", a status indicator "Active", and a profile picture for "Webmail Universitas Djuanda".

The left sidebar shows navigation options: Mail (99+), Compose, Mail, Chat, Spaces, and Meet. The main inbox area lists folders: Inbox (640), Starred, Snoozed, Sent, Drafts (8), and More. Labels are also visible.

The selected email is from "jurnal tep" with the subject "Ok. Thanks Berlomba-lombalah dalam berbuat kebajikan.... Mon, Sep 11, 10:52AM". The sender is "Helmi Haris <helmi.haris@unida.ac.id>" dated "Fri, Sep 15, 4:26 AM". The email body contains the following text:

Dear JTEP Editor,  
We hereby send the result of the improvements according to the text sent.  
Thank you.  
Best Regard

Helmi Haris

Below the text is an attachment section titled "One attachment • Scanned by Gmail". The attachment is a document titled "REVISI-CE 724..." with a Microsoft Word icon. A watermark "Activate Windows Go to Settings to activate Windows." is visible in the bottom right corner of the email content area.

The Windows taskbar at the bottom shows the search bar, task icons for File Explorer, Word, and Chrome, and system tray information including "EN", "27°C", and the date "10/17/2023".

## 1b.10.b. REVISED-CE 7244-20230731-WA0033

### Physicochemical Quality of Oyster Mushroom for Functional Food

Helmi Haris<sup>1</sup>, Ridwan Rachmat<sup>2</sup>, Tiana Fitrilia<sup>1</sup>, Ahmad Syarbaini<sup>1</sup>, Amar Ma'rif<sup>1</sup>, Dede Djuanda<sup>1</sup>, Dian Histifarina<sup>2</sup>, and Bagem Sembiring<sup>3</sup>

<sup>1</sup>University of Djuanda. Jl. Raya Ciawi Bogor, West Java. Indonesia

<sup>2</sup>Research Center for Appropriate Technology, National Research and Innovation Agency. Jl. K.S. Tubun No 5, Subang, West Java, Indonesia

#### ABSTRACT

This article presents studies on the physicochemical quality of oyster mushrooms grown within a housing and controlled by the Internet of Things (IoT). The goals of this study were to assess (1) the impact of indoor air quality on the growth and quality of mushrooms and (2) the antioxidant content of oyster mushrooms. In this study, the air temperature and humidity of oyster mushroom house per unit time was recorded and controlled automatically by an IoT system. Additionally, their physicochemical and microbiological quality were evaluated using physico-analytical instruments, and the potency of their ergothioneine (EGT) content was investigated using the HPLC method. The temperature of the air inside was between 29 and 35 °C, and the relative humidity was between 60% and 90%. The average texture of mushroom is soft. The average length, width, and height of the fresh mushroom were 41.5 mm, 60.0 mm, and 29.5 mm, respectively. The microbiological test confirmed that there was no salmonella infection in the collected mushrooms. The button-stage mushrooms have less total fungus than the bloom-stage mushrooms. The extraction standard method employs an EGT content of 0.674 mg/g as determined by chromatography data analysis. The oyster mushrooms can be consumed as a healthy meal, and the study of EGT showed also very prospective as one of immunotherapeutic food.

**Keywords:** ergothioneine, Fibre-reinforced plastic house, Internet of think, oyster mushrooms

#### 1. INTRODUCTION

The oyster mushroom is a type of mushroom that specifically grows in tropical countries such as Indonesia. Oyster mushrooms are grown on aggregate media one of them is the paddy waste from the paddy cultivation. Therefore, generally at the rice production centre area mostly becoming the centre for mushrooms production. This can be correlated with the availability of biomass as the main growing media for mushroom.

Cultivating high quality of the mushrooms required high-quality seeds, the high-quality media resources as well as the optimal environment due to the mushrooms are sensitive to climate change. To fulfil the optimum condition for mushrooms cultivation, an adequate production house is required to be implemented by environment controller and high-quality safety materials for growing media and to avoid using industrial in order to produce free contaminant (Kopinski & Kwiatkowska-Marks, 2012).

A prototype of Fiber Reinforced Plastic (FRP) house (Rachmat & Horibe, 1999) is a proper construction for mushroom production housing, and it is implemented with an Internet of things (IoT) based connected to various devices microcontroller. The mushroom production house used IoT control system to make it easier to monitor the air condition inside the house online by mean of displaying the

**Commented [NN1]:** Belum ada di Daftar Pustaka. Harap ditambahkan

**Commented [H2R1]:** Sudah ditambahkan :  
Rachmat, R., & Horibe, K. (1999). Solar heat collection characteristics of a fiber reinforced plastic drying house. *Transactions of the ASAE*, 42(1), 149-157.

value generated from the installed sensors inside the house. According to [Asyarita & Lestari \(2021\)](#), temperature and humidity in production house of mushrooms greatly affect the growth process of mushrooms. So that the mushrooms do not rot, brown and wilt, the humidity in the mushroom production house should not be too high or low, ranging from 75%-90% at the humidity level of the mushroom production house.

Research by [Dahiya et al. \(2019\)](#) who conducted an analysis of the efficiency of the edible mushroom stated that the growth of high consumption of mushrooms was due to the high protein content of edible mushrooms. The mushroom has good properties for the nutritional needs of the human body such as being rich in protein, vitamin C and various water-soluble vitamins (riboflavin, biotin and thiamine), fat (5.7%), carbohydrates (56,8%), amino acids, unsaturated fats, essential minerals (sodium, potassium and phosphorus) and has a low calorific value ([Ahlawat et al., 2016](#)).

Mushrooms contain various types of nutrients those are beneficial to the health of the human body, such as carbohydrates, proteins, and fats. Several types of essential nutrients found in edible mushrooms include amino acids (glutamic acid, proline, phenylalanine, lysine, histidine, etc.), fatty acids (lauric, palmitic, oleic, lenoleic, etc.), potassium, calcium, and phosphorus ([Adiandri et al., 2018](#)). One type of essential amino acid found in mushrooms is ergothioneine (EGT). EGT is a derivative of histidine which contains functional groups of sulfur atoms and hydrogen atoms (-SH) and it can only be synthesized by fungi and actinobacteria ([Borodina et al., 2020](#); [Halliwell et al., 2018](#)).

Mushrooms as a food source have been reported to have the highest level of ergothioneine compared to any other food source ([Dubost et al., 2006](#); [Dubost et al., 2007](#)). In an early report, it has been shown that if we consume mushrooms as our regular food, the bioavailability of ergothioneine remains in our body ([Weigand-Heller et al., 2012](#)). The ergothioneine chemical compound is accumulated in the fruiting bodies as well as in the mycelia of the mushroom ([Borodina et al., 2020](#); [Bellman et al., 2020](#)). Several studies have been conducted with samples of mushrooms to describe improved ergothioneine production by the addition of several additives, such as aspartic acid, lysine, and methionine, which demonstrate increased ergothioneine biosynthesis ([Lee et al., 2009](#)). In addition, it has also been described that the production of ergothioneine increases with increased pH and is higher under alkaline conditions ([Huang & Nie, 2015](#)).

Research on the identification and isolation of EGT from several fungal varieties has been carried out. The content of EGT in mushrooms is quite high and has good antioxidant activity. In addition, differences in genus and species of fungi have different chemical compositions contained in them so that it affects the proportion of EGT in mushrooms ([Kalaras et al., 2017](#)). The results of the literature study indicate that the identification and isolation of EGT from edible mushroom has never been done. Therefore, research to explore the opportunity to use edible mushroom as a source of EGT needs to be done.

The provision of production house that meets food safety requirements is absolutely necessary to produce safe oyster mushrooms for consumption. Meanwhile the technology development of this mushroom production that meets food safety standards for the isolation of ergothioneine as an antioxidant is a potential matter in exploration of mushroom is still limited. This paper describes the research results of the prototype of FRP house with the air condition variation inside the house and the effect of air condition against mushroom quality. The effect of the IoT implementation in controlling the air condition system as well as minimizing the human contact during oyster mushroom growing during cultivation periods, and to explore the value added of mushroom through the

**Commented [NN3]:** Belum ada di Daftar Pustaka. Harap ditambahkan

**Commented [H4R3]:** Sudah ditambahkan :  
Safitri, Shasha Asyarita., & Lestari, A. (2021). Uji Produktivitas Jamur Merang (*Volvariella volvacea*) Bibit F4 Asal Cilamaya Dengan Berbagai Konsentrasi Media Tanam Substitusi Tongkol Jagung. *Agrotekma: Jurnal Agroteknologi dan Ilmu Pertanian*, 5(2), 122-131.

**Commented [NN5]:** Belum ada di Daftar Pustaka. Harap ditambahkan

**Commented [H6R5]:** Dhiya et al (5) salah tulis, seharusnya Dahiya et al (2019)  
Sudah ditambahkan :  
Dahiya, S., Satyanarayana, T., & Singh, B. (2019). Thermophilic fungal diversity in sustainable development. *Microbial Diversity in Ecosystem Sustainability and Biotechnological Applications: Volume 1. Microbial Diversity in Normal & Extreme Environments*, 187-224.

**Commented [NN7]:** Belum ada di Daftar Pustaka. Harap ditambahkan

**Commented [H8R7]:** Sudah ditambahkan :  
Ahlawat, O. P., Manikandan, K., & Singh, M. (2016). Proximate composition of different mushroom varieties and effect of UV light exposure on vitamin D content in *Agaricus bisporus* and *Volvariella volvacea*. *Mushroom Res*, 25(1), 1-8.

**Commented [NN9]:** Belum ada di Daftar Pustaka. Harap ditambahkan

**Commented [H10R9]:** Sudah ditambahkan :  
Dubost, N.J., Ou, B. and Beelman, R.B., 2007. Quantification of polyphenols and ergothioneine in cultivated mushrooms and correlation to total antioxidant capacity. *Food chemistry*, 105(2), pp.727-735.

**Commented [NN11]:** 2019 atau 2020? Mohon klarifikasi  
Jika Referensi ini benar 2019, mohon ditambahkan ke Daftar Pustaka

**Commented [H12R11]:** Seharusnya Borodina et al (2020)  
Sudah ditambahkan :  
Borodina, I., Kenny, L. C., McCarthy, C. M., Paramasivan, K., Pretorius, E., Roberts, T. J., ... & Kell, D. B. (2020). The biology of ergothioneine, an antioxidant nutraceutical. *Nutrition Research Reviews*, 33(2), 190-217.  
*Kalaras et al (2020) seharusnya Beelman et al (2020)*  
Beelman, R. B., Kalaras, M. D., Phillips, A. T., & Richie, J. P. (2020). Is ergothioneine a 'longevity vitamin' limited in the American diet?. *Journal of nutritional science*, 9, e52.

ergothioneine (EGT) analysis as the of antioxidant content in mushroom. The scope of research includes (1) constructing a prototype of FRP house with IoT control system for oyster mushroom cultivation; (2) to evaluate the air condition variation inside the house and the effect of air condition against mushroom growth and quality; (3) Analysis of antioxidant content in mushroom.

## 2. MATERIAL AND METHODS

The research was conducted in 2022 at the field laboratory of Post Harvest Research Center of IAARD and analytical laboratory of University of Djuanda. The materials used in this research are analytical grade chemicals. The effectiveness of antioxidant properties on isolated EGT was measured by in vitro method. The main material and controlled apparatus respectively for (1) the construction material for building a prototype of FRP house with IoT control system for oyster mushroom cultivation; (2) The atmospheric air meter apparatus for investigating the air condition variation inside the house and the effect of air condition against mushroom growth and quality; (3) Analysis of antioxidant content in mushroom by HPLC method. The materials used in this research are analytical grade chemicals. The effectiveness of antioxidant properties on isolated EGT was measured by in vitro method.

### 2.1. FRP House

The Fibre Reinforced Plastic (FRP) house constructed (Figure 1) at an area of 650 cm x 350 cm with a light steel alloy frames and the roof is covered by a thin metal sheet roof and all each the wall blanketed by fibre reinforced plastic. (FRP), and white ceramic tile's floor. There are two shelves at inside the FRP house with of 400 cm length and 100 cm width respectively.

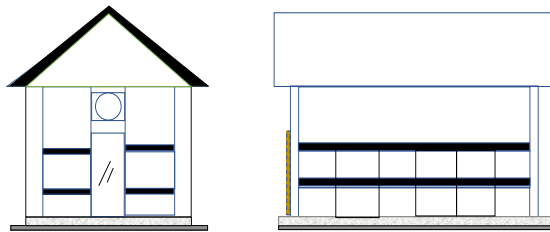

Figure 1. Prototype of FRP house model of straw mushroom (dimentions 3.0 m x 5.0 m x 3.0 m)

The FRP House implemented with an Internet of Think (IoT) system (Figure 2) to actuate a set of devices to measure the parameters of air temperature, air humidity, moisture content of the media. The control devices are 30 nozzles of mist sprayer setup along the rack of shelves above the media which are connected with a special hose. Hot air temperatures above 35 °C, caused the exhaust fan is on, whenever a drastic drop of air temperature inside the FRP house below 29 °C, thus the heater will operate automatically to increase the room temperature. The controller specification showed in Table 1 are set at day and night time with the elapsed time of intervals are enable to monitor the parameters conditions to avoid disturbance during mushrooms growth.

The Arduino Node MCU is an open-source platform based on IoT, which is able to implement various commands with programming languages. The application of the C programming language uses a sketch on the Arduino IDE (Integrated Development Environment), which is capable of programming



various kinds of microcontrollers including Node MCU. The Node MCU has a small size compared to Arduino UNO, by using the ESP8266 module, there are GPIO (General-purpose input/output), PWM (Pulse Width Modulation), I2C, UART (Universal Asynchronous Receiver Transmitter), 1-Wire and ADC (Analog to Digital Converter).

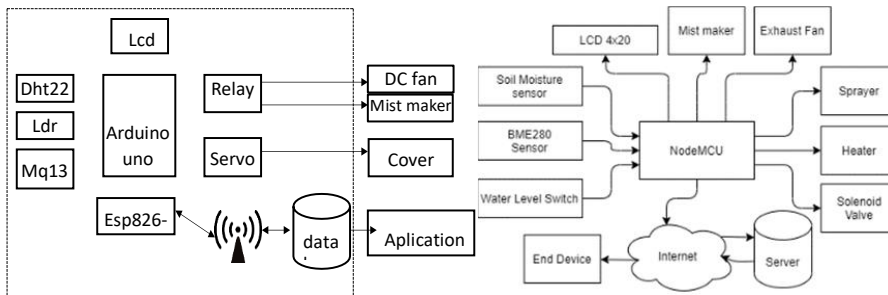

Figure 2. Architecture of IoT of production house in oyster mushroom

Tabel 1. Component and specification of control system

Component	Specifications
Sensor BME280	Air temperature and humidity sensor
Soil Moisture sensor	Soil moisture content controller
Water Level sensor	Water height controller
Mist-maker	Fog production and controller
Exhaust fan	Air humidity controller
Arduino IDE 1.8.9, fritzing	Temperature and humidity

**Commented [NN13]:** Semua Tabel dan Gambar harus disebut di dalam teks. Mohon ditambahkan

**Commented [H14R13]:** Sudah ditambahkan di teks

## 2.2. Cultivation Process Procedure

Mushroom cultivation process procedure was carried out inside FRP House and utilized the organic components which are mixed and fermentation process for 4 days to be a compost, and then fill into bag log evenly in a plastic sacks assembled inside FRP House. The layers of compost were pasteurized inside FRP house with closed cover condition tightly and then fogging with hot air at temperature 60 to 65 °C for 8 hours. The mushroom seeds were inside over the bag logs of compost and then to be incubated for 3 days at around 29-30 °C of inside air temperature. The treatment during mushroom growth up to harvest periods comprised of the inside air temperature, humidity and soil water content. The treatment during mushroom growth up to harvest periods comprised of the inside air temperature, humidity by thermos-hygrograph and soil water content sensor at every 20 min. The first harvesting conducted two weeks after seedling where the growth mushroom head is indicated by totally white head blooming.

## 2.3. Extraction of the Active Compound Ergothioneine

Ergothioneine is a complex compound of antioxidant. The isolation of ergothioneine EGT compounds from the harvested fresh mushrooms was carried out by the extraction method refers to the method

developed by [Ito et al. \(2011\)](#) and [Nguyen et al. \(2012\)](#) with some modifications. Pre-treatment (blanching and non-blanching), mushroom before drying methods by electric oven drying.

The experimental factors of extraction employed the temperature 40°C and 60°C respectively with the variation of the extraction solvent (water and ethanol 30% (v/v), 50% (v/v), 70% ethanol (v/v), and ethanol 100% (v/v)). The extraction procedure utilized 10 grams of dry mushroom powder and 200 mL of solvent which has been heated in a shaking water bath according to variations in temperature. The solvent along with the solute was continuously agitated at 100 rpm for 1 hour, then cooled at room temperature for 2 hours. Then it was centrifuged at 600 rpm for 15 minutes at 25°C. The achieved of the process is supernatant which was transferred to a conical tube for further evaporation using a vacuum evaporator at a temperature of 40°C to evaporate the remaining solvent up to be a paste of EGT extract. Furthermore, the paste of EGT was dried by the freeze-drying method. The dried EGT sample was then weighed to measure as the extraction yield.

#### 2.4. EGT concentration analysis

Analysis of the concentration of EGT in the oyster mushroom extract used the HPLC method referring to the method used by [Kalaras et al. \(2017\)](#) with some modifications. The mushroom powder (0.5 g) and 7 ml of **ethanol** was put into a 15 ml centrifuge tube (consisting of 10 mM dithiothreitol, 100 M betaine, 100 M 2-mercapto-1-methyl imidazole) and 3 ml of distilled water was added and homogenized with a vortex for 10 seconds. A total of 2 mL of 1% SDS solution dissolved in ethanol was added and homogenized with a vortex for 10 seconds. Then the suspension was centrifuged for 20 minutes at 4000 rpm and 25°C. The supernatant formed was transferred to a 15 mL centrifugation tube. Then, 1 mL of the supernatant was put into a micro tube and allowed to stand for 24 hours. The solid formed from this process is then dissolved into 0.5 mL of aqua bides and homogenized using a vortex until it dissolves completely. Samples that have been stored in micro-tubes were centrifuged at 10,000 rpm for 1 minute. The supernatant formed was then filtered using a syringe filter (0.45 100 m) and put into a glass vial for HPLC analysis.

HPLC analysis was performed using column C18. The volume of the solution injected was 10 µL. The mobile phases used mobile phase A (3% acetonitrile, 0.1% TEA, 50 mM dibasic sodium phosphate dissolved in distilled water), mobile phase B (acetonitrile), and mobile phase C (water). The separation was performed on the elution gradient as follows: 0 minutes 15:85 (B:C), 0-5 minutes set at a slope of 5:15:85 (A:B:C), 5-6 minutes set at a slope of 10:90 ( B:C), 6-8 minutes at 3:97 (B:C), and 8-15 at 3:97 (B:C). EGT was detected at a wavelength of 254 nm with a peak retention time of 5.7 min which was quantified using an external standard curve.

The antioxidant activity of EGT from edible mushroom was carried out by measuring the radical scavenging activity of DPPH referring to the method of [Pahila et al. \(2019\)](#). The analytical procedure comprised of 50 L of straw mushroom extract is added to 50 L of DPPH solution (100 M in 85% ethanol) and stirred using a vortex. After 15 minutes, the solution mixture was put into a 50 L Pyrex NMR capillary tube, then the DPPH radical spin resonance was measured with a spectrometer at a wavelength of 517. The spectrometer settings as microwave power, 1.2 mW; microwave frequency 9149.3 MHz; field magnet, 325.5 25 mT; and the sweep time, 30 seconds. Various concentrations of EGT were measured for resonance to construct a standard curve. The radical scavenging activity of DPPH was expressed as mmol equivalent of EGT per mL of sample.

### 3. RESULTS AND DISCUSSION

#### 3.1. FRP House

The prototype of the FRP house is shown in Figure 3. Condition of the air temperature, air humidity and water content of the media inside the FRP house during mushroom cultivation are monitored automatically. The variation of air temperature around 29-39°C is relatively stable, while condition at day, night and rainy, resulted in high fluctuated of air humidity 40-98% with the water content of the media around 39-99%.

The devices inside the mushroom's FRP house consists of circuits, input blocks and output blocks which are joint by the Nodemcu microcomputer to control the air condition inside mushroom's FRP house. The input block is a soil moisture sensor and BME280 as a temperature, humidity and barometric detector. The sensor will generate an input value for the Nodemcu microcomputer, this value will be processed by Nodemcu which produces an output value to the connected devices. While the output block is a receiver a value generates by sensor through Nodemcu, such as a heater will operate if the temperature inside the mushroom's FRP house is low and the mist-maker will turn off if the humidity inside the mushroom's FRP house is sufficient. Nodemcu has a Wi-Fi module that is able to save the values and data in the database, this can make it easier to use a smartphone to access mushroom's FRP house condition even the values or data remotely. The IoT control system is setup for operating the hot air exhaust with the mist sprayer process taking place in parallel if the air temperature at above 39 °C with humidity below 60%. And when the opposite condition occurred (below 29 °C), thus the water heater will actively operate spraying hot air vapor into the FRP House. This methods of IoT control mechanism will reduce the human intervention so that the growth process of mycelium and pinhead of fungal embryos can achieve optimally.

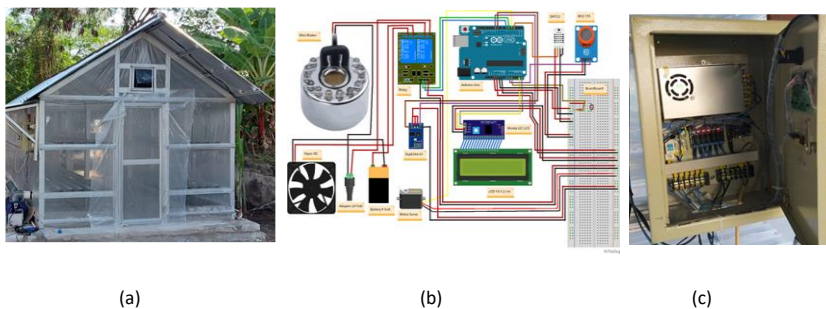

Figure 3. The prototype of the FRP house (a) with IoT circuit (b) and panel control box (c)

The generated measuring instrument and sensors performance corresponded the proposed elapsed time through the interface to display's monitor. In table 2 showed the comparison of sensor values with measuring instruments. Digital measuring instrument used to compare sensor values such as hygrometer, lux meter and the average temperature difference of 0.92 °C and humidity of 2.1%.

Table 2. Temperature and humidity sensor testing

Temperature			Humidity		
Sensor	Device	Diff	Sensor	Device	Diff
31.7	30.8	0.9	77	76	1
31.6	30.7	0.9	78.3	77	1.3
31.7	30.7	1	78.9	78	0.9

31.8	30.7	1.1	78.3	78	0.3
31.8	30.7	1.1	79.1	79	0.1
31.8	31.3	0.5	80.2	79	1.2
32.2	31.1	1.1	83.4	82	1.4
32.2	31.2	1	82	82	0
32.1	31.5	0.6	81.3	81	0.3
32.1	31.1	1	81.2	81	0.2

**Table 3** is a comparison graph of sensor values with measuring instruments. Digital measuring tools used to compare sensor values such as mini-Hygrometer, lux meter and carbon detector. The test was carried out by taking samples 30 times by getting an average temperature difference of 0.91 °C, humidity 0.89%. Furthermore, the light sensor gets an average difference of 19.76% and gas content of 10.13 ppm. The second test evaluates the performance of the tool and obtains an accuracy rate of success of 93.3%.

Table 3. Light sensor and CO<sub>2</sub> content

light			Gas Content		
Sensor	Device	Diff	Sensor	Device	Diff
192	175	17	21	10	11
187	144	43	33	12	21
182	152	30	16	9	7
103	100	3	24	16	8
170	145	25	22	20	2
-	-	-	-	-	-
-	-	-	-	-	-
144	124	20	18	7	11
169	123	46	10	3	7
118	115	3	15	8	7
124	121	3	24	16	8
128	122	6	30	20	10

### 3.2. Effect of FRP House on Mushroom quality

Air conditions and lighting inside mushroom's FRP house day and night during the mushroom growth (Figure 4) contribute for the effect to the quality of harvested fresh mushroom. The results of quality analysis indicated that the range of phenotype length of 2.5-10 cm, diameter of 3-10 cm and weight 10-120 gram (Figure 5), in general the mushrooms growth from organic media are longer and heavier than non-organic growth media with more uniform dimensions except for the diameter of phenotype. Figure 4. is to show the effect of air condition mentioned by sensors to the growth of the mushroom,

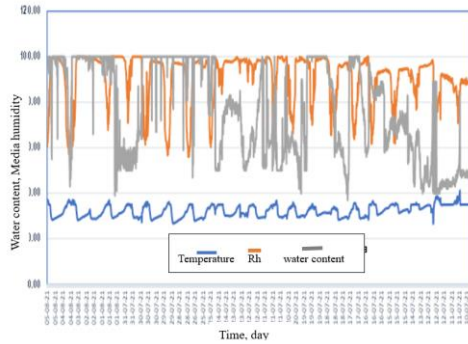

Figure 4. Fluctuation of air temperature, RH, and moisture content inside FRP House

Commented [NN15]: Semua komponen gambar agar diinggriskan: waktu, suhu, kadar air, kelembaban  
Perhatikan juga sumbu Y

Commented [H16R15]: Sudah di Inggriskan di teks (Figure 4)



Figure 5. Dimension of harvested oyster mushroom

The hardness test and the moisture content of the mushrooms were carried out by comparing the mushrooms at the farm level as shown in Table 4, indicating that the mushrooms in the FRP house were harder and less water content than that ones at the farmer mushroom’s housing at the farm level.

Table 4. Characteristics of straw mushroom

No	Parameter	average
1.	texture	Soft
2.	Dimension	
	- Length (mm)	41.5±6.0
	- Width (mm)	60.0±4.0
	- Height (mm)	29.5±9.0

### 3.3. Micro Laboratory Analysis

The results of micro-laboratory analysis (Table 5) showed that the fresh harvested mushroom are negative from total fungus and salmonella

Tabel 5. Analysis result of total fungus and salmonella

Code	Phase of fungus	Total fungus (CFU/g)	<i>Salmonella</i> (negative/25g)
A	Non organic mushroom, Bloom	2.9x10 <sup>5</sup>	negative
B	Non organic mushroom, fresh	1.0x10 <sup>5</sup>	negative
C	Organic mushroom, bloom	3.5x10 <sup>4</sup>	negative
D	Organic mushroom, fresh	6.5x10 <sup>4</sup>	negative
E	non organic mushroom, bloom	1.7x10 <sup>6</sup>	negative
F	non organic, mushroom, fresh	5.4x10 <sup>4</sup>	negative

#### 3.3.1. Active Compound Ergothioneine

The results of the analysis on functional compounds of EGT in oyster mushrooms using the HPLC method, a graphic recording of the results of HPLC analysis of dried mushrooms with standard ethanol solvent. The average recording results from the EGT chromatography results were 0.674 mg/g as shown in Table 6.

Table 6. Results of chromatogram graphic data processing from mushroom extract

Code	Area	Intercept	Slope	V (ml)	fp	B.s (g)	C (ppm)	C (%)	mg/g DW
Organic, et 70%	2.005	0.1501	0.0643	20	250	0.2006	719032.64	71.90	0.799
	2.0309	0.1501	0.0643	20	250	0.2006	729072.50	72.91	0.810
Non organic, et 70%	2.2289	0.1501	0.0643	20	250	0.2688	601370.99	60.14	0.668
	2.2626	0.1501	0.0643	20	250	0.2688	611119.98	61.11	0.679
Ethanol 96%	2.2255	0.1501	0.0643	20	250	0.2034	793432.33	79.34	0.882
	2.0676	0.1501	0.0643	20	250	0.2034	733066.64	73.31	0.815
Powder, organic	1.3702	0.1501	0.0643	20	250	0.2022	469216.53	46.92	0.521
	1.3862	0.1501	0.0643	20	250	0.2022	475369.69	47.54	0.528
Powder, anorganic	1.3431	0.1501	0.0643	20	250	0.2009	461763.43	46.18	0.513
	1.2709	0.1501	0.0643	20	250	0.2009	433817.65	43.38	0.482

The extraction process breaks down the bonds among the molecules of the material so that EGT and phenol compounds are produced with varying concentrations depending on the type of solvent used (Table 7). The results of the standard solution analysis showed that the EGT compound had a retention time of 3.33 ± 0.06 minutes, while the mushroom sample showed a retention time of 3.28 to 3.30 minutes.

Table 7. Recapitulation of EGT characterization data from edible mushrooms

Solvent	Concentration EGT (mg/g DW)	Total Phenol (mg/g DW)
Ethanol 96%	0.805 ± 0.01	0.015 ± 0.00
Ethanol 70%	0.848 ± 0.05	0.025 ± 0.00

The extraction process using 70% ethanol produced higher concentrations of EGT and phenol than the extraction process using 96% ethanol. This shows that 70% of ethanol solvent is more effective used to bind EGT and phenol compounds in oyster mushrooms than that in pure solvents. This result is in line with the previous study conducted by [Nguyen et al. \(2012\)](#). The process of extracting the *Flammulina velutipes* mushroom using 70% ethanol was able to produce EGT and phenol compounds with higher concentrations than that the extraction using 50% and 100% of ethanol, with values of  $2.05 \pm 0.18$  mg/g and  $3.65 \pm 0.08$  DW, consecutively.

The extraction process that has been carried out can break down the bonds between the molecules of the material so that EGT and phenol compounds are produced with varying concentrations depending on the type of solvent used ([Table 8](#)). The results of the standard solution analysis showed that the EGT compound had a retention time of  $3.33 \pm 0.06$  minutes, while the straw mushroom sample showed a retention time of 3.28 to 3.30 minutes.

Table 8. Methods and varying concentrations type of solvent for EGT

Mushroom species	Methods	Ergothioneine concentration (mg/g dw)
<i>Flammulina velutipes</i> ( <a href="#">Nguyen et al., 2012</a> )	Water	$1.50 \pm 0.21$
	Ethanol 70%	$2.05 \pm 0.18$
	Methanol 70%	$1.86 \pm 0.04$
	Acetone 70%	$1.92 \pm 0.07$
<i>Pleurotus eryngii</i>	Hot water ( <a href="#">Yen et al., 2018</a> )	0.86
<i>Pleurotus citrinopileatus</i>	Hot water ( <a href="#">Yen et al., 2018</a> )	3.73
<i>Oyster Mushroom</i>	Ethanol 70%	$0.67 \pm 0.01$

The extraction process for active compounds ([Table 9](#)), such as EGT and phenol, is influenced by several factors, such as solvent polarity and process conditions. A mixture of solutions has the ability to bind the active compound better than the pure solvent. This is due to the mixing of nonpolar solvents with water which can increase the polarity index of the solvent so that the extraction efficiency increases.

In addition, the increase in extraction temperature was positively correlated to the increase in antioxidant activity and polyphenols (flavonoids and total phenol), while the increase in extraction time was not positively correlated to the increase in antioxidant activity and polyphenols. In addition, the presence of agitation during the extraction process also contributes to increasing the extraction yield. This happens because the agitation process can increase the rate of diffusion and minimize the barriers to mass transfer from the solid surface into the solution ([Muhamad et al., 2014](#)).

Table 9. Results of chromatograph analysis of mushroom samples

Code	Area	V (ml)	fp	B.s (g)	C (ppm)	C (%)
Organic	2.0050	20	250	0.20	719032.6	71.90
Non organic	2.2289	20	250	0.27	601371.0	60.14
Ethanol 96%	2.2255	20	250	0.20	793432.3	79.34
Powder (organic)	1.3702	20	250	0.20	469216.5	46.92
Powder (unorganic)	1.3431	20	250	0.20	461763.4	46.18

**Commented [NN17]:** Belum ada di Daftar Pustaka. Harap ditambahkan

**Commented [H18R17]:** Sudah ditambahkan : Muhamad, N., Muhmed, S. A., Yusoff, M. M., & Gimbun, J. (2014). Influence of solvent polarity and conditions on extraction of antioxidant, flavonoids and phenolic content from Averrhoa bilimbi. *Journal of Food Science and Engineering*, 4, 255-260.

Table 10 showed that the role in synthesizing EGT is the methyltransferase enzyme which is encoded by the EGT gene and specifically remodels histidine into EGT compounds (Stampfli et al., 2020). The results of another study stated that the biosynthesis of EGT is a complex synthesis process involving various types of amino acids and carbon sources. However, in principle there are three types of amino acids that play an important role in EGT biosynthesis, namely methionine, histidine, and cysteine. Histidine acts as a starting material that plays a role in the whole series of EGT biosynthesis. Cysteine serves to provide a source of sulfur atoms, while methionine which contains the protein S-adenosyl-l-methionine (SAM) acts as a precursor in reactions involving methyl groups. In supporting its growth, cells can use dextrose, fructose, glycerol, maltose, and sucrose as carbon sources. A suitable carbon source for EGT biosynthesis is glycerol because it is able to maintain cells in a longer stationary growth phase. In the glycolysis cycle, glycerol is broken down into glycerol-3 phosphate by the enzyme glycerol kinase. Furthermore, glycerol-3 phosphate is broken down by the enzyme glyceraldehyde-3 phosphate dehydrogenase to glyceron-P which is then overhauled by triosephosphate isomerase to glyceraldehyde 3 phosphate (GAP). GAP acts as a precursor in the glycolysis process to produce pyruvic acid which will also be a substrate in the Krebs cycle. Consumption of large amounts of pyruvic acid can stimulate enzymatic reactions of amino acids to produce EGT (Yu et al., 2020).

Table 10. Concentration of ergothioneine in different mushroom species (Lee et al., 2009; Ito et al., 2011).

Mushroom Species	Ergothioneine Content*	Mushroom Species	Ergothioneine Content*
<i>Fomitopsis pinicola</i>	0.07 ± 0.01	<i>Polyozellus multiplex</i>	0.51 ± 0.01
<i>Ganoderma applanatum</i>	0.06 ± 0.02	<i>Ramaria botrytis</i>	0.29 ± 0.03
<i>G. lucidum</i>	0.08 ± 0.02	<i>S. granulatus</i>	0.09 ± 0.03
<i>G. neo-japonicum</i>	0.07 ± 0.00	<i>Lampteromyces japonicus</i>	0.43 ± 0.16

\*mg/g dw; Mean ± SD.

#### 4. CONCLUSION

The research results showed that the cultivation of oyster mushroom in an FRP house with ceramic floors and plastic walls and an IoT management. The temperature of the air inside was between 29 and 35 degrees Celsius, and the relative humidity was between 60% and 90%. The average texture of fresh oyster mushroom was soft. The average length, width, and height of the fresh mushroom were 41.5 mm, 60.0 mm, and 29.5 mm, respectively. The microbiological test confirmed that there was no salmonella infection in the collected mushrooms. The stage of mushrooms have less total fungus than the bloom-stage mushrooms. The extraction standard method employs an EGT content of 0.674 mg/g as determined by chromatography data analysis. The oyster mushrooms can be consumed as a healthy meal, and the study of EGT showed also very prospective as one of immunotherapeutic food.

#### REFERENCES

Adiandri, R.S., Hidayah, N., dan Nugraha, S. (2018). Identification of amino acid, fatty acid, mineral content and respiration rate of straw mushroom in different stage of maturity. *Proceeding the International Seminar on Tropical Horticulture*, 239-248.

**Commented [NN19]:** Belum ada di Daftar Pustaka. Harap ditambahkan

**Commented [H20R19]:** Sudah ditambahkan : Stampfli, A. R., Blankenfeldt, W., & Seebeck, F. P. (2020). Structural basis of ergothioneine biosynthesis. *Current Opinion in Structural Biology*, 65, 1-8.

**Commented [NN21]:** Belum ada di Daftar Pustaka. Harap ditambahkan

**Commented [H22R21]:** Sudah ditambahkan : Yu, F., Song, J., Liang, J., Wang, S., & Lu, J. (2020). Whole genome sequencing and genome annotation of the wild edible mushroom, *Russula griseocamosa*. *Genomics*, 112(1), 603-614.

**Commented [NN23]:** Jumlah References min 20 dari jurnal. Selebihnya boleh dari Buku, Report, Statistik, Standard, Thesis. Reference dg highlight kuning tidak ditemukan di dalam teks (tidak dirujuk). Jika memang digunakan agar ditempatkan dalam teks yang sesuai. Di dalam teks terdapat beberapa Rujukan yang belum ada di Daftar References (mohon ditambahkan).

**Commented [H24R23]:** Reference dg highlight kuning yang tidak ditemukan di dalam teks (tidak dirujuk) sudah dihapus. Sedangkan beberapa Rujukan yang belum ada di Daftar References sudah ditambahkan, sehingga sudah ada 20 References yang berasal dari jurnal,



- Ahluwat**, O. P., Manikandan, K., & Singh, M. (2016). Proximate composition of different mushroom varieties and effect of UV light exposure on vitamin D content in *Agaricus bisporus* and *Volvariella volvacea*. *Mushroom Res*, 25(1), 1-8.
- Beelman**, R. B., Kalaras, M. D., Phillips, A. T., & Richie, J. P. (2020). Is ergothioneine a 'longevity vitamin' limited in the American diet?. *Journal of nutritional science*, 9, e52.
- Borodina**, I., Kenny, L.C., McCarthy, C.M., Paramasivan, K., Pretorius, E., Roberts, T.J., van der Hoek, S.A., & Kell, D.B., (2020). The biology of ergothioneine, an antioxidant nutraceutical. *Nutrition Research Reviews*, 33(2), 190-217. <https://doi.org/10.1017/s0954422419000301>
- Dahiya**, S., Satyanarayana, T., & Singh, B. (2019). Thermophilic fungal diversity in sustainable development. *Microbial Diversity in Ecosystem Sustainability and Biotechnological Applications: Volume 1. Microbial Diversity in Normal & Extreme Environments*, 187-224.
- Dubost**, N.J., Beelman, R.B., Peterson, D., & Royse, D.J. (2006). Identification and quantification of ergothioneine in cultivated mushrooms by liquid chromatography-mass spectroscopy. *International Journal of Medicinal Mushrooms*, 8(3), 215-222. <http://dx.doi.org/10.1615/IntJMedMushr.v8.i3.30>
- Dubost**, N.J., Ou, B. and Beelman, R.B., 2007. Quantification of polyphenols and ergothioneine in cultivated mushrooms and correlation to total antioxidant capacity. *Food chemistry*, 105(2), pp.727-735.
- Halliwell**, B., Cheah, I.K., & Tang, R.M.Y. (2018). Ergothioneine – A diet-derived antioxidant with therapeutic potential. *FEBS Letters*, 592(20), 3357-3366. <https://doi.org/10.1002/1873-3468.13123>
- Huang**, X., & Nie, S., (2015). The structure of mushroom polysaccharides and their beneficial role in health. *Food & function*, 6(10), 3205-3217. <https://doi.org/10.1039/c5fo00678c>
- Ito**, T., Kato, M., Tsuchida, H., Harada, E., Niwa, T., & Osawa, T. (2011). Ergothioneine as an anti-oxidative/anti-inflammatory component in several edible mushrooms. *Food Science and Technology Research*, 17(2), 103-110.
- Kalaras**, M.D., Beelman, R.B., Holick, M.F., & Elias, R.J. (2012). Generation of potentially bioactive ergosterol-derived products following pulsed ultraviolet light exposure of mushrooms (*Agaricus bisporus*). *Food chemistry*, 135(2), 396-401. <https://doi.org/10.1016/j.foodchem.2012.04.132>
- Kalaras**, M.D., Richi, J.P., Calcagnotto, A., & Beelman, R.B. (2017). Mushrooms: A rich source of the antioxidants ergothioneine and glutathione. *Food Chemistry*, 233, 429-433. <https://doi.org/10.1016/j.foodchem.2017.04.109>
- Kopinski**, L., & Kwiatkowska-Marks, S. (2012). Utilization of waste newspaper using oyster mushroom mycelium. *Industrial & Engineering Chemistry Research*, 51(11), 4440-4444. <https://doi.org/10.1021/ie202765b>
- Lee**, S.H., Hwang, H.S., & Yun, J.W., (2009). Antitumor activity of water extract of a mushroom, *Inonotus obliquus*, against HT-29 human colon cancer cells. *Phytotherapy Research*, 23(12), 1784-1789. <https://doi.org/10.1002/ptr.2836>
- Muhamad**, N., Muhmed, S. A., Yusoff, M. M., & Gimbin, J. (2014). Influence of solvent polarity and conditions on extraction of antioxidant, flavonoids and phenolic content from *Averrhoa bilimbi*. *Journal of Food Science and Engineering*, 4, 255-260.
- Nguyen**, T.H., Nagasaka, R., & Ohshima, T. (2012). Effects of extraction solvents, cooking procedures and storage conditions on the contents of ergothioneine and phenolic compounds and antioxidative capacity of cultivated mushrooms *Flammulina velutipes*. *International Journal of Food Science & Technology*, 47(6), 1193-1205. <https://doi.org/10.1111/j.1365-2621.2012.02959.x>

- Pahla**, J., Ishikawa, Y., & Ohshima, T. (2019). Effects of ergothioneine-rich mushroom extract on the oxidative stability of astaxanthin in liposomes. *Journal of Agricultural and Food Chemistry*, **67**(12), 3491-3501. <https://doi.org/10.1021/acs.jafc.9b00485>
- Rachmat**, R., & Horibe, K. (1999). Solar heat collection characteristics of a fiber reinforced plastic drying house. *Transactions of the ASAE*, **42**(1), 149-157.
- Safitri**, Shasha Asyarita., & Lestari, A. (2021). Uji Produktivitas Jamur Merang (*Volvariella volvacea*) Bibit F4 Asal Cilamaya Dengan Berbagai Konsentrasi Media Tanam Substitusi Tongkol Jagung. *Agrotekma: Jurnal Agroteknologi dan Ilmu Pertanian*, **5**(2), 122-131.
- Weigand**-Heller, A.J., Kris-Etherton, P.M., & Beelman, R.B. (2012). The bioavailability of ergothioneine from mushrooms (*Agaricus bisporus*) and the acute effects on antioxidant capacity and biomarkers of inflammation. *Preventive Medicine*, **54**, S75-S78. <https://doi.org/10.1016/j.ypmed.2011.12.028>
- Stampfli**, A. R., Blankenfeldt, W., & Seebeck, F. P. (2020). Structural basis of ergothioneine biosynthesis. *Current Opinion in Structural Biology*, **65**, 1-8.
- Yen**, M. T., Chang, Y. H., Huang, S. J., Cheng, M. C., & Mau, J. L. (2018). Extraction of ergothioneine from *Pleurotus eryngii* and *P. citrinopileatus* (Agaricomycetes) and preparation of its product. *International Journal of Medicinal Mushrooms*, **20**(4).
- Yu**, F., Song, J., Liang, J., Wang, S., & Lu, J. (2020). Whole genome sequencing and genome annotation of the wild edible mushroom, *Russula griseocarnosa*. *Genomics*, **112**(1), 603-614.



## 1b.12. a. Bukti Publied JTEP Vol. 12, No. 4 (2023) 818 – 830

The screenshot displays the website for the Journal of Teknik Pertanian Lampung (JTEP). The page is titled "JURNAL TEKNIK PERTANIAN LAMPUNG" with ISSN 2302 - 559X (print) and ISSN 2549 - 0818 (online). The main content area is for "VOL 12, NO 4 (2023) DECEMBER 2023". It features a "TABLE OF CONTENTS" section with three articles listed, each with a PDF icon and page numbers. The articles are: 1. "Determination of Suitable Plant Types in an Irrigation Command Area Using IWQI Method" by Sri Wahyuningsih, Elida Novita, and Reo Nurdiansyah Ramadhan (pages 795-806). 2. "Addition of Essential Oil Bioadditives as a Mixture of Biodiesel B35 Fuel on the Performance of Reducing Water content and Particulate Content" by Anggi Firdaus Agmusah, Meika Syahbana Fusi, Dwi Setyaningsih, Egi Agustian, and Ade Kurniawan (pages 807-817). 3. "Physicochemical Quality of Oyster Mushroom for Functional Food" by Helmi Haris, Ridwan Rachmat, Tiana Fitriha, Almad Syarbaini, Amar Ma'ruf, Dede Djuanda, Dian Histifarina, and Bagem Sembiring (pages 818-830). The page also includes navigation menus, a sidebar with indexing logos (DOAJ, CABI, Google Scholar, Crossref, Sinta, Garuda, Dimensions), and a right sidebar with a certificate of accreditation and an article template icon. The Windows taskbar at the bottom shows the date as 10/17/2023 and the time as 11:08 AM.

OPEN JOURNAL SYSTEMS

NOTIFICATIONS  
View (2 new)  
Manage

INDEXING JOURNAL

DOAJ DIRECTORY OF OPEN ACCESS JOURNALS

CABI

Google Scholar

Crossref

Sinta

GARUDA

Dimensions

HOME ABOUT USER HOME SEARCH CURRENT ARCHIVES

ANNOUNCEMENTS

Home > Archives > Vol 12, No 4 (2023)

**VOL 12, NO 4 (2023)**

DECEMBER 2023

TABLE OF CONTENTS

ARTICLES

Determination of Suitable Plant Types in an Irrigation Command Area Using IWQI Method Sri Wahyuningsih, Elida Novita, Reo Nurdiansyah Ramadhan	PDF 795-806
Addition of Essential Oil Bioadditives as a Mixture of Biodiesel B35 Fuel on the Performance of Reducing Water content and Particulate Content Anggi Firdaus Agmusah, Meika Syahbana Fusi, Dwi Setyaningsih, Egi Agustian, Ade Kurniawan	PDF 807-817
Physicochemical Quality of Oyster Mushroom for Functional Food Helmi Haris, Ridwan Rachmat, Tiana Fitriha, Almad Syarbaini, Amar Ma'ruf, Dede Djuanda, Dian Histifarina, Bagem Sembiring	PDF 818-830

00588455 JTEP Stats

Sertifikat Akreditasi

Article Template

ADDITIONAL MENU

TEMPLATE

EDITORIAL TEAM

AUTHOR GUIDELINES

REVIEWERS LIST